

OPERATION INSTRUCTION



MIDI/SUPRA V2

Code **PM.9.005082.EN**

Version -

Date **03.10.2022**



* P M . 9 . 0 0 5 0 8 2 . E N *

Door drive



safety in motion™

Product manufacturer reference can be found on the product type label. For any support or further questions please contact your trading office.



No part of this publication may be reproduced or translated, even in part, without prior written permission from WITTUR. Subject to change without notice!

© Copyright WITTUR 2016



WITTUR

Producttitle

Sheet **PM.9.005082.EN.02**
Version **-/03.10.2022**
Date **03.10.2022**
Approved **WATMZe**

Document type

Content

1. General information prior to install

1.1	Description and function.....	4
1.2	Liability and guarantee	4
1.3	Safety precautions	4
1.4	Related documents.....	4
1.5	Preparation for operation.....	4
1.6	Delivery.....	4

2. Electronic assembly layout

3. Commissioning

3.1	Power Supply	6
3.2	DC-Voltage Supply or Emergency battery drive.....	6
3.3	Safety Circuit	6
3.4	Driving the doors with the elevator controller Parallel IO.....	6
3.5	Driving the doors with the elevator controller CAN BUS	7
3.6	Driving the doors by the Test drive buttons	7

4. Adjustments always to be done

4.1	Adjustment of the speed.....	7
-----	------------------------------	---

5. Description of LED's

5.1	LED's Inputs	8
5.2	LED's Outputs.....	8
5.3	Other LED's	8
5.4	CAN Led's.....	9

6. Electrical Interface

6.1	Inputs	9
6.2	Passenger protection device input and supply	9
6.3	Outputs.....	10

7. DIP Switches

8. Trouble shooting

8.1	The door does not move	11
8.2	Faults causing reset or switch off	12
8.3	Faults decreasing performance of door	13
8.4	Reset of coupler width.....	13
8.5	Reset of all door parameters	13



WITTUR

MIDI/SUPRA V2

Operation Manual

Sheet	PM.9.005082.EN.03
Version	-/03.10.2022
Date	03.10.2022
Approved	WATMZe

Content

9. Exchange of electronic box

9.1	Preparation for learning of door parameter	14
9.2	Learning of coupler width and door width	15
9.3	Learning of door width only.....	15

10. Wiring diagram MIDI V2 and SUPRA V2

11. Wittur Programming Tool Interface Software Description

11.2	Connecting the Wittur Programming Tool to the SUPRA-electronic	17
11.3	Menu structure of programming tool	17
11.4	Door adjustment with the WITTUR Programming Tool (WPT)	18
11.5	Preventive Maintenance tool	25
11.6	WPT Condition Monitoring	30



WITTUR

MIDI/SUPRA V2

Operation Manual

Sheet	PM.9.005082.EN.04
Version	-/03.10.2022
Date	03.10.2022
Approved	WATMZe

1. General information prior to install

1.1 Description and function

WHD SUPRA/MIDI V2 car door operators are used for mid and high duty elevators. The Drive can move panel masses up to 600kg complete door package weight.

1.2 Liability and guarantee

This instruction handbook is written for people who are familiar with lift servicing and installation. Sufficient knowledge of lifts is essential. WITTUR accept no responsibility for damage caused by improper handling, or for damage caused as a result of actions other than those stated in these operating instructions. The WITTUR guarantee may be voided if parts other than those described in these instructions are installed.

1.3 Safety precautions

WITTUR machine installation or repair engineers are chiefly responsible for the safe operation of machinery. It is essential to comply with and keep abreast of all safety rules and legal obligations in order to avoid personal / product damage during installation, maintenance and repair work.

Important safety advice and danger warnings are emphasized with the following symbols:

 General danger warning

 High danger risk warning (i.e. crushing edge, cutting edge etc.).

 Risk of damage to machinery parts (i.e. due to incorrect installation, or such like).

 Important information sign

1.4 Related documents

Catalog TC.9.005083.EN
Service tool instruction PM.9.00.5182 english
Software update manual PM.9.006255.EN

1.5 Preparation for operation

Before installation work begins, it is in your own interests to clarify what structural and spatial conditions are available for installation work, so that you can see which installation procedures should / must be carried out. Therefore it is recommended that all circumstances be taken into consideration, and to mentally plan the installation sequence before any rash or badly planned work is carried out. Check the goods or parts for correct and full delivery upon receipt.

Following tools are needed:

- "T"-handled hexagon keys 4 mm, 5 mm and 6 mm
- Screw drivers (flat and crossheaded)

The drive unit is preadjusted at the factory. No other mechanical and electrical adjustments other mentioned in this instruction are required at site!

1.6 Delivery

Complete preassembled drive unit. Only to be stored in the original package (plastic wrap). The components must not be unpacked until the installation begins.



WITTUR

MIDI/SUPRA V2

Operation Manual

Sheet PM.9.005082.EN.05
Version -/03.10.2022
Date 03.10.2022
Approved WATMZe

2. Electronic assembly layout

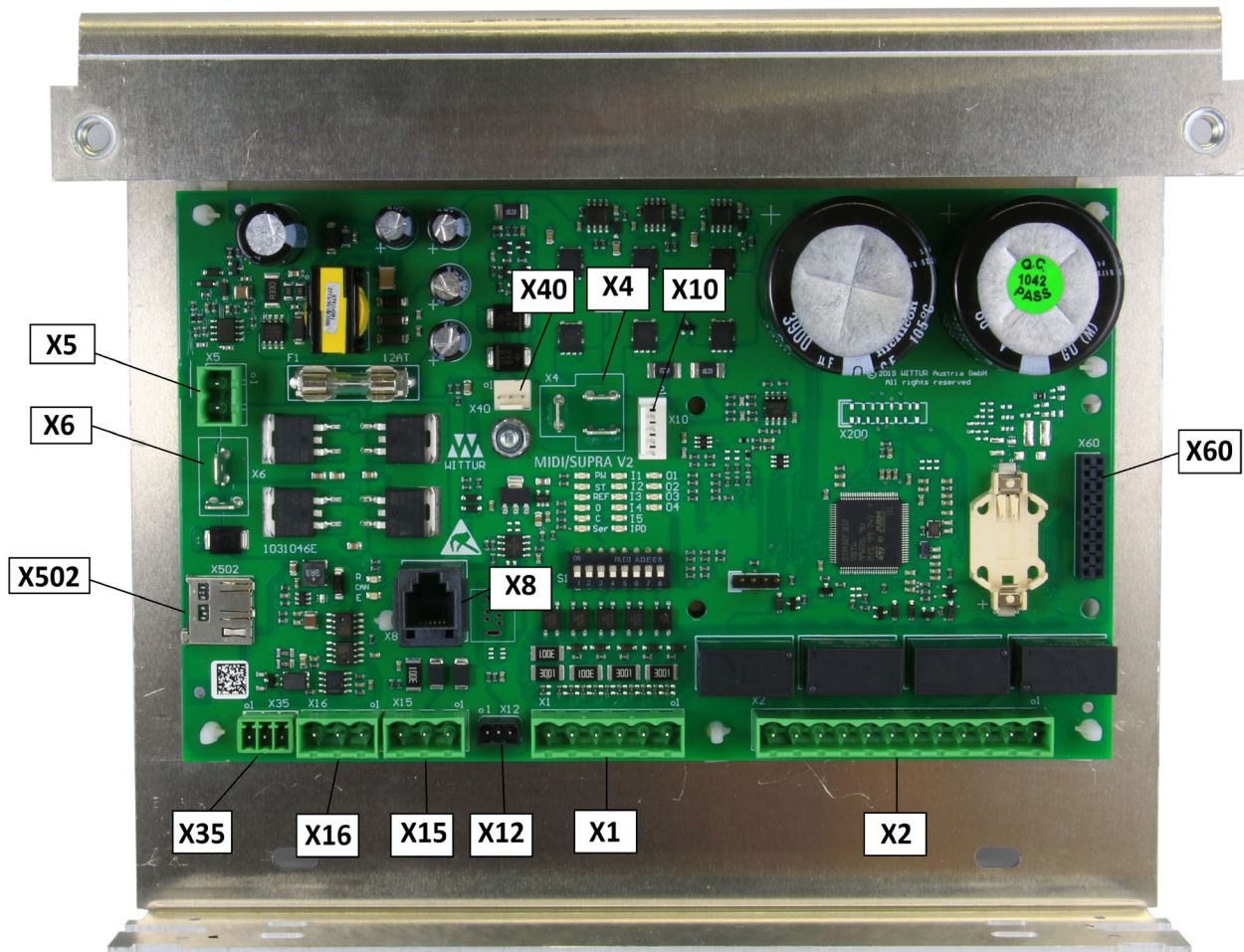

Plug description:

- | | |
|--|------------------------------|
| X1 - Inputs | X10 - Encoder |
| X2 - Outputs | X12 - Reference Switch |
| X4 - Motor | X15 - Photo Cell receiver |
| X5 - Battery supply (option) | X16 - Photo cell transmitter |
| X6 - Transformer secondary winding | X35 - CAN Communication |
| X8 - RS485 interface for WPT (Wittur Programming Tool) | X40 - Test drive Buttons |
| X502 - SD Card Slot for updating | X60 - Extension plug |



WITTUR

MIDI/SUPRA V2

Operation Manual

Sheet **PM.9.005082.EN.06**
Version **-/03.10.2022**
Date **03.10.2022**
Approved **WATMZe**

3. Commissioning

Door operators are delivered directly from the factory, are pre-adjusted.
For readjusting see chapter 9.2 Learning of door parameter, readjusting of learning parameters is only needed in case of spare part electronics, or exchanging electronics from other mechanics.

3.1 Power Supply

The WHD-MIDI/SUPRA V2 - drive provides transformers for both different voltage ranges 115/230VAC.

Line in supply is connected to Terminal Plug D1

Select the recommended fuse for the nominal voltage range, see table

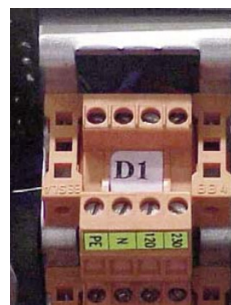

Nominal Supply Voltage	120Vac	230Vac
Automatic fuse slow (in control panel)	6A	4A
Minimum cable required	1,5mm²	1mm²

3.2 DC-Voltage Supply or Emergency battery drive

Terminal X5 is used for DC-Voltage or battery supply. For DC-Voltage Supply following values are needed for the supply: 24V-48V with nominal power of 200W for Supra motor and 150W for MIDI motor, the supply has to cover peak power of 650W for Supra motor and 450W for Midi motor.

For emergency battery drive, the door can be driven, if supplied by e.g. 2x12V 7,2Ah. Also all door protective devices (which where connected to the door itself) are active during battery drive. The door has to be controlled by normal open/close commands.

3.3 Safety Circuit

The door contacts are prewired to Terminal Plug D2.
Safety contact ratings: Min. 5Vdc - Max. 250Vac 2A

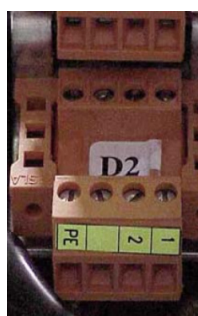



WITTUR

MIDI/SUPRA V2

Operation Manual

Sheet	PM.9.005082.EN.07
Version	-/03.10.2022
Date	03.10.2022
Approved	WATMZe

3.4 Driving the doors with the elevator controller Parallel IO

- Connect the signals from the elevator controller to connector X1 and X2 of the door operator.
- Refer to the project delivery documents for the wiring diagram between the elevator controller and door operator (see also connection diagram in chapter *10 Wiring diagram MIDI and SUPRA V2*).
- Check if service LED(Ser) is off, see chapter *5.3 LED's Outputs*

- If the door is not at reference switch position (near by close end, door panels closed) after power up and CLOSE command is active (LED „C“ on), the door will move at low speed as long as the reference switch is found.
- After finding the reference switch and the mechanical close end the door drive will start with the next OPEN command in direction open with normal speed drive until the mechanical end is found.
- Then the door will drive with normal speed in both directions.
- Check that the safety devices (photo cells, light barrier or close force limiter) reopen the door (see DIP-switch description see *7. DIP Switches*).
- According to the DIP-Switch adjustment (S1/2) the door is reopend by the elevator control or automatically by the door itself.

3.5 Driving the doors with the elevator controller CAN BUS

- Connect the CAN Bus to the plug X35(see also connection diagram in chapter 10 Wiring diagram MIDI and SUPRA V2), make sure the cabeling is correct.
- The default Baud rate is 250kBit/s, the baudrate can be changed by the service tool. See 1.4 Related documents
- Check if the CAN RUN LED („R“ Green) is on (CAN Cummunication is OK) and the Can Error LED is off („E“ Red) see 5.4 CAN Led's
- If the door is not at reference switch position (near by close end, door panels closed) after power up and CLOSE command is active (LED „C“on), the door will move at low speed as long as the reference switch is found.
- After finding the reference switch or the mechanical close end the door drive will start with the next OPEN command in direction open with normal speed drive until the mechanical end is found.
- Then the door will drive with normal speed in both directions.
- Check that the safety devices (photo cells, light barrier or close force limiter) reopen the door (see DIP-switch description see *7. DIP Switches*).
- According to the DIP-Switch adjustment (S1/2) the door is reopend by the elevator controller or automatically by the door itself.

3.6 Driving the doors by the Test drive buttons

- The Test drive buttons only work when the Test button operation switch (S1/1) is active (the inputs I1 Open, I2 Close, I3 Nudging, I4 and I5 are deactivated in this case,the door drive does also not react on CAN commands) Entering the test drive mode is also possible by pressing both test drive button for at least 2sec. The motor will react by vibrating for one time. To relase the test drive mode press again both test drive button for at least 2sec. The motor will react by vibrating for one time.
- Check that the door is moving in open and close direction, according the pressed service drive button.
- In this mode of operation the reopening of the door by a safety device is not activated.

4. Adjustments always to be done

4.1 Adjustment of the speed

The drive electronic offer to select one out of four different speed levels (for handicap elevators or other purpose). Look at DIP switch description (chapter 7) and adjustment.



MIDI/SUPRA V2

Operation Manual

Sheet PM.9.005082.EN.08
Version -/03.10.2022
Date 03.10.2022
Approved WATMZe

5. Description of LED's

5.1 LED's Inputs

Name	LED illuminated if
I1	Input 1 is active (connected to COM)
I2	Input 2 is active (connected to COM)
I3	Input 3 is active (connected to COM)
I4	Input 4 is active (connected to COM)
I5	Input 5 is active (connected to COM)
IPD	Input passenger protection device (photo cell or curtain of light)

5.2 LED's Outputs

Name	LED illuminated if
O1	Output 1 is active (connected to COM)
O2	Output 2 is active (connected to COM)
O3	Output 3 is active (connected to COM)
O4	Output 4 is active (connected to COM)

5.3 Other LED's

Name	LED illuminated if
POWER	Power Supply is OK
WDOG	if microcontroller doesn't work
STATE	on: door is not learned/ referenced off: door is learned/referenced blinking: error codes 1x flashing: Motor/Encoder fault 3x flashing: internal fault 4x flashing: abnormal operation 5x flashing: fault during learning
REFSW	Door is in Reference Switch area
C	a close command is applied (Bus communication, Parallel IO's or service drive buttons)
O	an open command is applied (Bus communication, Parallel IO's or service drive buttons)
Ser	on: door drive is in service drive mode off: door drive is in normal operation flashing: door is in auto mass detection mode



WITTUR

MIDI/SUPRA V2

Operation Manual

Sheet PM.9.005082.EN.09
 Version -/03.10.2022
 Date 03.10.2022
 Approved WATMZe

5.4 CAN Led's

LED	Description
R	CAN RUN LED according CIA 303-3
E	CAN Error LED according CIA 303-3

During auto Baudrate dedection mode both LEDS „R“ and „E“ are flashing alternately.

6. Electrical Interface

6.1 Inputs

The inputs are activated if they are connected to COM

Terminal	Symbol	Name of terminal	Explanation
COM	COM	Common	Common line for I 1...I 5
I1		Open	This command will drive the door in open direction until the open position is reached. Depending on the setting of DIP switch S1/8 the door is kept open by motor torque also without command.
I2		Close	This command will drive the door in close direction until close position is reached and coupler is operated. Depending on the setting of DIP switch S1/8 the door is kept closed by motor torque also without command
I3		Nudging	Nudging input, puts the door to slow speed drive in close direction. Smoke sensitive devices like photo cell or light barrier (input IPD) and close force reopen will be ignored.
I4		Inspection	By setting this input the test drive buttons are activated. The command inputs at X1 are inactivated. Same function as DIP switch S1/1.
I5		High Speed	By setting this input a higher speed can be selected (same function as DIP switch S1/6). This input is effective only when DIP switch S1/6 is switched OFF.

6.2 Passenger protection device input and supply

The input is activated if it is connected to GND.

Terminal	Name of Terminal	Explanation
+24V	+24V	+24V DC supply for photo cell or curtain of light (max. 150mA)
IPD	Photo Cell	Input for photo cell or curtain of light, light barrier or other passenger protection device
GND	GND	Ground for supply of photo cell or curtain of light (light barrier)
N.C.	Not Connected	Can be used as terminal for light barrier (no internal connection)



WITTUR

MIDI/SUPRA V2

Operation Manual

Sheet PM.9.005082.EN.010
 Version -/03.10.2022
 Date 03.10.2022
 Approved WATMZe

6.3 Outputs

The outputs are relays where the 3 contact pins are wired to the terminals. (01 to 04 = common, NC = normally closed, NO = normally opened) see chapter 10 Wiring diagram MIDI/SUPRA V2

Terminal	Name of terminal	Explanation
01	Open End	The open end output indicates the fully open position of door panels.
02	Close End	The close end output indicates the fully close position of door panels.
03	Reopen	the reopen output is switched in case the IPD input is active
04.	Position	the position output can be used for special signals for the operating with the lift controller. Standard function is called Position out and means a signal adjustable right before the door panel is closed.

7. DIP Switches

	ON	OFF
S1/1	Service activated	Normal operation
S1/2 (***)	Automatic reopen/reclose on obstruction or IPD (Reopen 03 is switched as long as reopen is in progress)	No automatic reopen/reclose (only Reopen 03 is switched)
S1/3	Automatic end keeping timeout disabled (For discrete IO usage)	Automatic end keeping timeout enabled (For CAN communication usage)
S1/4	rear door (only used with CAN communication)	front door (only used with CAN communication)
S1/5	Speed adjustment, see figure below	
S1/6		
S1/7 (**)	Open force limitation activated	No open force limitation
S1/8 (*)	Automatic end keeping in close/open end	Hold open/closed only on active open/close command

Speed Setting:

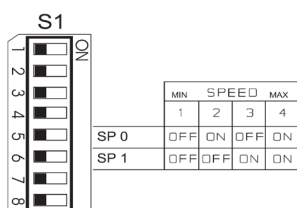

* For the compliance to EN81-20 (part. 5.3.15.1) the switch S1/8 must be OFF

** For the compliance to EN81-20 (part. 5.3.6.2.2.1 only glas doors) the switch S1/7 must be ON

*** In case of automatic reopen/reclose, O3 is set if an obstacle is detected and switch off after reopen. In case of no automatic reopen/reclose, O3 switch on when an obstacle is detected, and switch off when the obstacle is removed or a reclose/reopen command is applied from the liftcontroller.



To be compliant with ASME 17.1 / CSA B44 it is mandatory to switch off S1/2



WITTUR

MIDI/SUPRA V2

Operation Manual

Sheet	PM.9.005082.EN.011
Version	-/03.10.2022
Date	03.10.2022
Approved	WATMZe

8. Trouble shooting

There is a fault if the STATE LED is blinking. The number of flashes (below indicated by a number in brackets) gives a hint about the type of error. See chapter 5.3. The fault codes can be read by WPT.

8.1 The door does not move

8.1.1 The door does not move at all

- Check that the power is on. The POWER LED „PW“ must light up if X19 is connected and the circuit breaker in the elevator control panel is on.
- Check that the motor and encoder wires are connected correctly (plug X4 and X10) and the motor is not overheated.
- Check that the control panel is sending an open or close command (I1-I2/X1, LED I1, I2). According the given command, the LED Open „O“ / Close „C“ should be on and the LED service drive mode „SER“ should be off. In case „SER“ is on, please leave the service drive mode.
- Check if there is too high friction if door is moved manually. If the STATE LED flashes read the faults by using WPT.
- Check if the open force limitation is deactivated (S1/7 off).

8.1.2 The door does not open

- Check that the OPEN command LED I1 lits up, when an open command is present (I1/X1 connected to COM).
- Check that the CLOSE command LED I2 does not light up
- Check that the car and landing door locks are not jammed.
- Check, when the open force limitation is active (S1/7 ON), that the friction is not too high.
- Check according the given command also the LED Open „O“ and Close „C“

8.1.3 The door does not close

Check that the CLOSE command LED I2 lits up when the input I2/X1 is switched on COM.
The close force may be too low (or friction too high).

8.1.4 The door only partly opens or closes

Check that the open and close signal times (LEDs I1, I2) from the elevator controller are long enough. The door moves only as long as command is set.

8.1.5 The door does not reopen/reclose

- If no automatic reopen/reclose is selected (DIP Switch S1/2 is OFF), :
- For reopen/reclose the elevator controller must remove the close/open command and activate the open/close command.
- To reopen/reclosing the door the elevator controller must receive either a reopen/reclose request signal from the door electronics (REOPEN output O3) or from an independently wired safety device (e.g. photocell or Curtain of light ...).
- If automatic reopen/reclose is selected (DIP Switch S1/2 is ON):
An automatic reopen/reclose process is caused by the input IPD or by the close/open force limiter.
Check the following reopen devices:
 - Photocell or curtain of light (not defect or dirty).



WITTUR

MIDI/SUPRA V2

Operation Manual

Sheet	PM.9.005082.EN.012
Version	-/03.10.2022
Date	03.10.2022
Approved	WATMZe

-Close force limiter (friction is not too high).

Check the following reclose devices:

-Open force limiter (friction is not too high).

8.2 Faults causing reset or switch off

-Over current (e.g. power stage or motor short circuit)

-Motor or encoder short circuit, open wires and/or missing signals (1).

-Internal electronic fault

-Undervoltage (supply voltage is measured and the power stage switches off if the voltage is too low).

-Mechanical end not found ($\geq 3,5m$).

-Door mechanically blocked.

8.3 Faults decreasing performance of door

-Motor and/or power stage temperature too high. The software reduces the power of the motor (power stage). If temperature is nevertheless exceeding a higher limit, power stage is shut down for cooling down a certain time (4).

-Low voltage supply like battery drive or low line voltage.

-Reference switch faulty (5). (I2/X1 not connected to COM). A close command overrides the open command.

8.4 Reset of coupler width

If the coupler width must be reset (e.g. remove or change of coupler system.....) continue like described below:
Before "Reset of coupler width" is done, do preparation for learning described in paragraph 9.1, item 3 and 4 page 15 (manual closing of door panels, but don't close coupler vanes!).

By pressing the learn button for at least 10 seconds (until STATE LED flashes fast) the coupler width is cleared and a new learning is started.

After resetting the coupler width, continue with start-up procedure like described in paragraph 9.2 "Learning of door parameter" starting with item 2.

8.5 Reset of all door parameters

(this function can only be activated by service tool, see item "11.4.2.2 Reset to default")



WITTUR

MIDI/SUPRA V2

Operation Manual

Sheet PM.9.005082.EN.013
Version -/03.10.2022
Date 03.10.2022
Approved WATMZe

9. Exchange of electronic box

9.1 Preparation for learning of door parameter

1. DIP switch setting has to be copied from the replaced board, see chapter 7: "DIP-Switches".
2. Mount the reference switch in any way, that the switch and magnet are opposite when the door panels are closed
3. Service Drive has to be activated.
4. Put the door panels to fully closed position (1). Check that the coupler is opened (2) (landing lock un locked). Therefore open the door panels by hand and push them manually to closed position. The hanger plate (truck) must touch the close end buffer. See picture below (1)

Strut-Coupler System

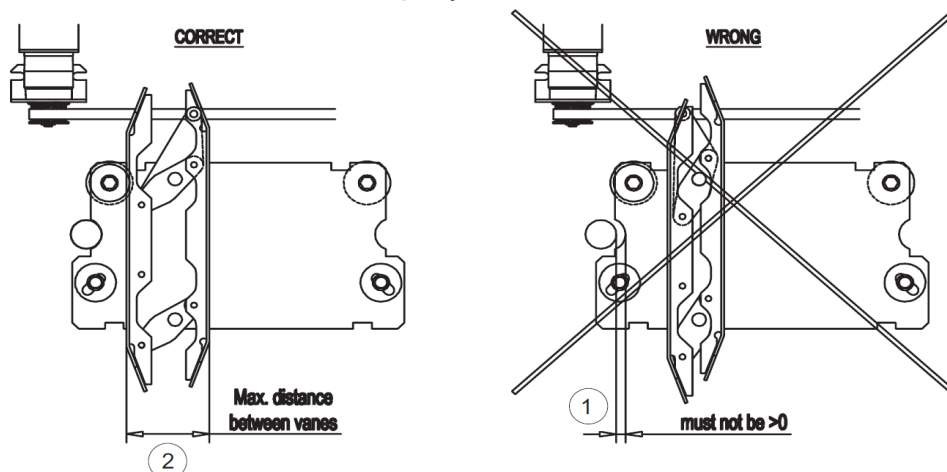

Close-Coupler System

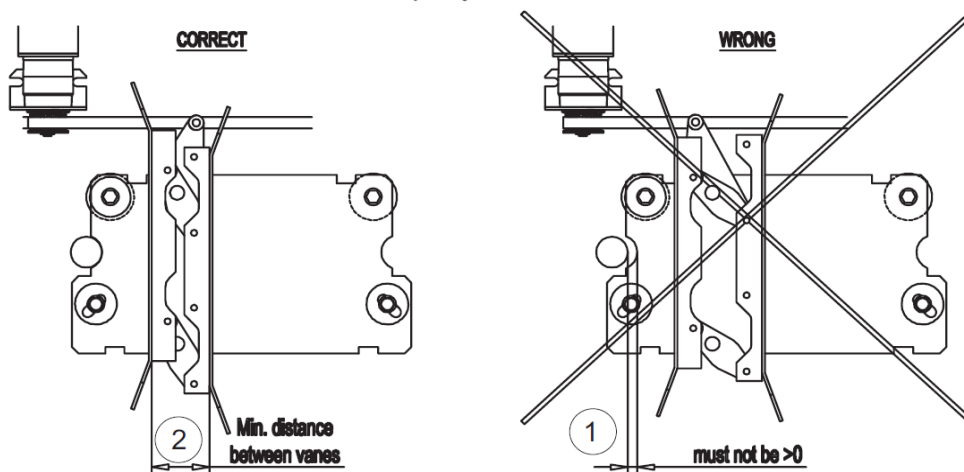



WITTUR

MIDI/SUPRA V2

Operation Manual

Sheet PM.9.005082.EN.014
Version -/03.10.2022
Date 03.10.2022
Approved WATMZe

9.2 Learning of coupler width and door width

1. Switch power on, move door out of reflash area (REF LED has to be off)
2. Move the door by hand in close direction until door is fully closed.(REF LED is on)
3. Press both test drive buttons for at least 1 seconds until the motor starts vibrating 1 time.
4. Press both test drive buttons for at least 6 seconds until the motor starts vibrating 4 time.
5. Release one of the testdrive button (keep pressing one of them) door starts automatic learning.
6. Hold the button till the door finished learning cycles (at least two door openings)
7. Release the test drive button after the the vibration of the motor signaled end of learning.
8. Press both service drive Buttons to release the service mode

9.3 Learning of door width only

1. Switch power on.
2. Press both test drive buttons for at least 1 seconds until the motor starts vibrating 1 time.
3. Press both test drive buttons for at least 6 seconds until the motor starts vibrating 3 time.
4. Release one of the testdrive button (keep pressing one of them) door starts automatic learning. Attention the door is moving as long as one of the service drive buttons is pressed. in case of any mechanical malfunction, release the button and the door stops.
A short stop of the door movement will not lead to canceling the automatic learning procedure.
5. Hold the button till the door finished learning cycles (at least two door openings)
6. Release the test drive button after the the vibration of the motor signaled end of learning.
7. Press both service drive Buttons to release the service mode

9.4 Learning door width and coupler width without reference sensor.

1. Switch on S1/1 and turn on power
2. Move door in close end position
3. Repeat steps from 4-8 from 9.2.Learnig of coupler width and door width

see short description:

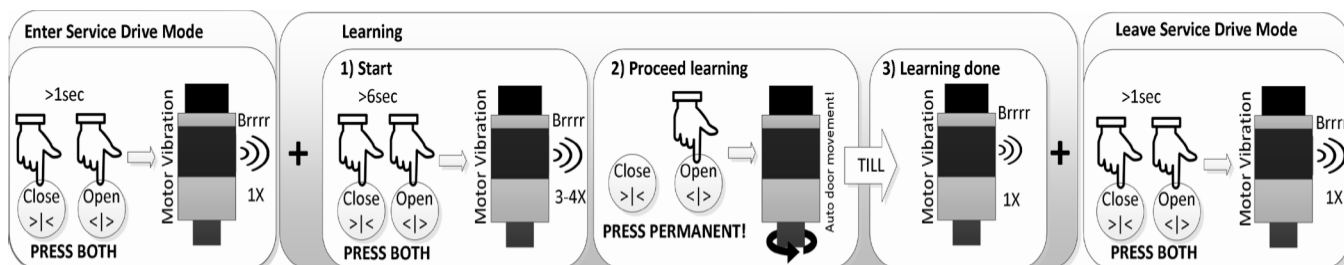



WITTUR

MIDI/SUPRA V2

Operation Manual

Sheet **PM.9.005082.EN.015**
 Version **-/03.10.2022**
 Date **03.10.2022**
 Approved **WATMZe**

10. Wiring diagram MIDI V2 and SUPRA V2

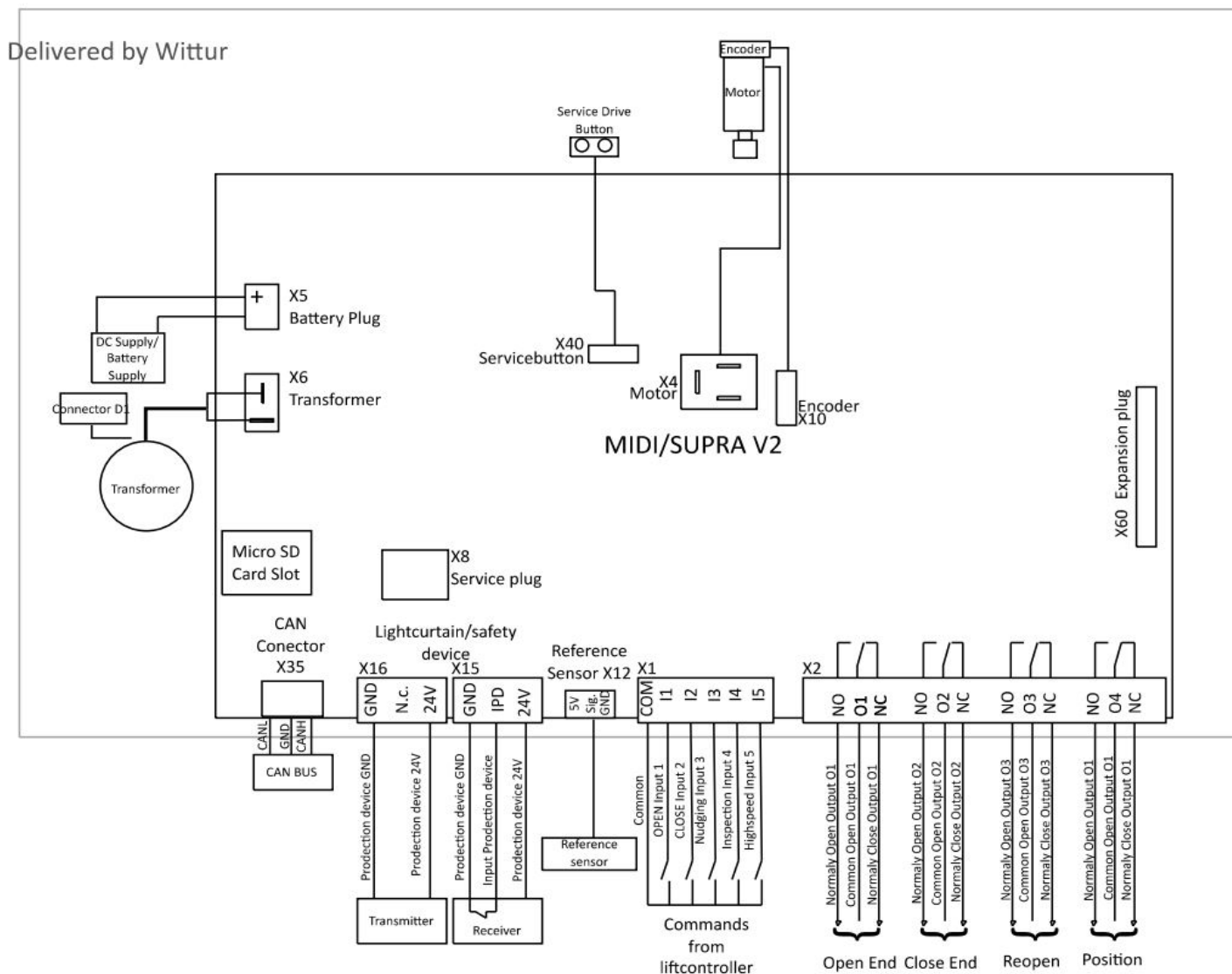

Plug description:

- X1 - Inputs
- X2 - Outputs
- X4 - Motor
- X5 - Battery supply (option)
- X6 - Transformer secondary winding
- X8 - RS485 interface for WPT (Wittur Programming Tool)
- X502 - SD Card Slot for updating
- X10 - Encoder
- X12 - Reference Switch
- X15 - Photo Cell receiver
- X16 - Photo cell transmitter
- X40 - Test drive Buttons
- X60 - Extension plug



WITTUR

MIDI/SUPRA V2

Operation Manual

Sheet PM.9.005082.EN.016
Version -/03.10.2022
Date 03.10.2022
Approved WATMZe

11. Wittur Programming Tool Interface Software Description

11.1 Introduction

The MIDI+ / SUPRA-electronic is equipped with a serial communication interface RS 485 to watch/modify data stored in the electronic. Some data (for example the speed values) are stored in a memory which is independent from power supply, this memory is called EEPROM. For use of the WITTUR Programming Tool (WPT) see Operating instructions D276Mxx.

Languages available: F1: GB

11.2 Connecting the Wittur Programming Tool to the SUPRA-electronic

The WITTUR Programming Tool can be connected directly to the MIDI+ / SUPRA board at the plug X8, there are no further adjustments necessary. Switch off the WPT before connecting it to door drive.

11.3 Menu structure of programming tool

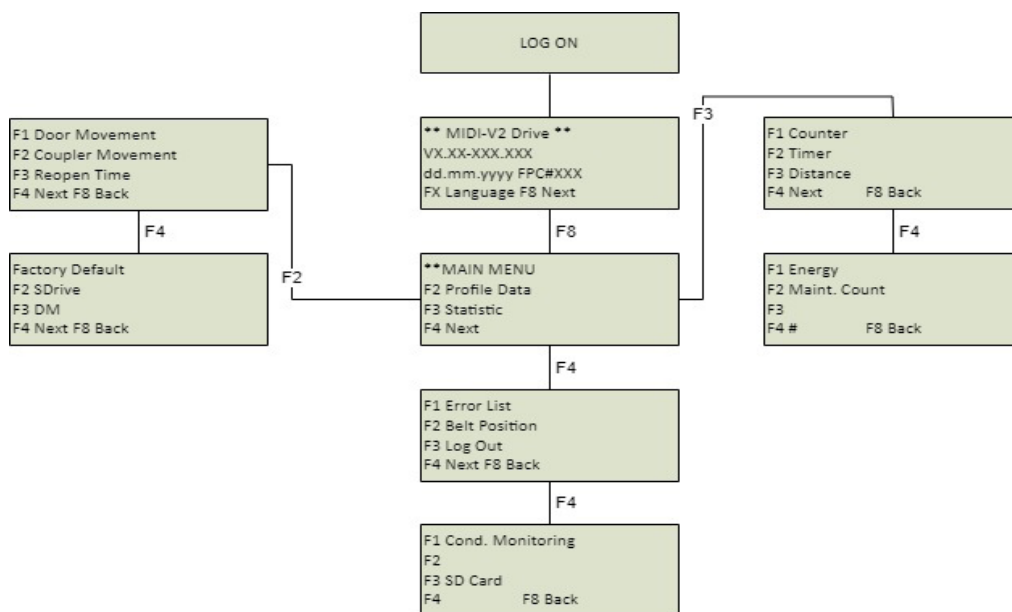



WITTUR

MIDI/SUPRA V2

Operation Manual

Sheet PM.9.005082.EN.017
Version -/03.10.2022
Date 03.10.2022
Approved WATMZe

11.4 Door adjustment with the WITTUR Programming Tool (WPT)

11.4.1 Login of the WITTUR Programming Tool

Press the 'ON'-button longer than 2 seconds until you can see the log-in Display.

The screen after power on login shows: motor type, language, door drive software revision and date. The user language of WPT can be changed by pressing the function buttons F1..F6 on the WPT.

- Languages available:

- 'F1' GB English
- 'F2' DE German
- 'F3' IT Italian
- 'F4' FR French
- 'F5' ES Spanish
- 'F6' TR Turkish

```
** MIDI-V2 Drive**  
VX.XX -WIT.YYY  
dd.mm.yyyy, FPC#XXX  
FX Language        F8 Next
```

VX.XX..... Software version (for example 1.0A)
WIT.... Firmware Version (Wittur)
YYY....Firmware Subversion (for example Std for standard)
dd.mm.yyyy.... Date of software version
FPC#XXX..... FPC program version (for example FPC#018)

After pressing 'F8' the initial menu screen appears

```
** MAIN MENU  
F2 Profile Data  
F3 Statistic  
F4 Next
```

Press 'F2' or 'F3' to select one of the menu items or use 'F4' to view additional screens

```
F1 Error List  
F2 Belt Position  
F3 Log Out  
F4 Next        F8 Back
```

```
F1 Cond. Monitoring  
F2  
F3 SD card  
F4            F8 Back
```

'F8' jumps back to the last screen, or F4 next to enter the next screen.



WITTUR

MIDI/SUPRA V2

Operation Manual

Sheet PM.9.005082.EN.018
Version -/03.10.2022
Date 03.10.2022
Approved WATMZe

11.4.2 'F2': Profile Data

F1 Door Movement
F2 Coupler Movement
F3 Reopen Time
F4 Next F8 Back

This menu allows you to call up 2 further menus: 'F1' Door Movement und 'F2' Coupler Movement. 'F4' to enter next screen.

F1 Factory Default
F2 SD
F3 DM
F4 Next F8 Back

This menu allows you to call up 2 further menus: 'F1' Factory Reset 'F2' SD and 'F3' DM.

11.4.3 'F3': Reopen Time

Reopen Time is the waiting period after the reopen in open end, before the door closes again. By pressing 'F3' the parameter Reopen Time can be watched and changed.

Reopen Time:
000.0s
Enter Ch. F8 Back

To enter a new value press the number keys, after that press 'ENTER'. This value is taken over in a buffer and carried out.

Reopen Time:
001.5s
Enter Ch. F8 Back

By leaving this menu with 'F8' you will be asked if the entered value shall be stored permanently to the memory.



MIDI/SUPRA V2

Operation Manual

Sheet PM.9.005082.EN.019
Version -/03.10.2022
Date 03.10.2022
Approved WATMZe

Use changed Value?
YES/NO F8 Back

By pressing the keys 'YES' / 'NO' the value can be used / rejected.

11.4.4 'F4': Next (Profile Data)

F1 Reset to Default
F2 SD
F3 DM
F4 F8 Back

The door parameter are resetted to its initial value by pressing the button 'F1'.

11.4.5 'F1': Reset to default

Reset to Default?
YES/NO F8 Back

By pressing the 'YES' button all the adjusted parameters are cleared and overwritten by default values.

11.4.6 'F2': SD

Butt on?
YES/NO F8 Back

By pressing YES you enter the service mode, next screen wil show following:

Learn?
YES/NO F8 Back

By pressing YES, Learning is tarted, to finish the learning, press one of the service drive buttons during till the door finished learning.



MIDI/SUPRA V2

Operation Manual

Sheet **PM.9.005082.EN.020**
Version **-/03.10.2022**
Date **03.10.2022**
Approved **WATMZe**

11.4.7 'F3': DM

DM:
0000.0 kg

F8 Back

This screen shows the actual moving mass.

11.4.8 'F1': Door Movement

F1 Open Speed
F2 Close Speed
F3 Nudging Speed
F4 Next F8 Back

This menu allows you to watch/modify values described in the following chapters by pressing the corresponding function key. See chapter 11.4.2.1 how to enter values. All these variables are stored in the EEPROM. Speed values for speed adjustment 1-3 (see chapter 7) are calculated from values of speed setting 4 by multiplying with fix constants (see chapter 12).

11.4.9 'F1 Open speed' - Open speed.

Top speed for open movement; speed setting 4.

11.4.10 'F2 Close speed' - Close speed

Top speed for close movement; speed setting 4.

11.4.11 'F3 Nudging speed' - Close speed for nudging

Top speed for close movement with nudging command speed setting 4.

11.4.12 'F4': Next (Door Movement)

F1 Brake Parameter
F2 Position Out
F3 Acceleration
F4 F8 Back

This menu allows you to watch/modify values described in the following chapters by pressing the corresponding function key.



WITTUR

MIDI/SUPRA V2

Operation Manual

Sheet PM.9.005082.EN.021
Version -/03.10.2022
Date 03.10.2022
Approved WATMZe

11.4.13 `Brake Parameter`

This parameter influences the delay and creep to the open / close end. The possible adjustment range is '0'..'9', the earliest brake is reached with parameter '0' and the latest delay is reached with parameter '9'.

11.4.14 `Position Out` Relay output

By entering this parameter the Position output O4 can be adjusted to switch at any door position. Standard adjustment is 0 (deactivated).

11.4.15 `Acceleration`

By adjusting this parameter the acceleration of the door can be changed. The adjustment is done in m/sec².

11.4.16 `F2`: Coupler Movement

F1 Coupler Speed
F2 Coupler Width
F3 Acceleration
F4 F8 Back

This menu allows you to watch/modify values described in the following chapters by pressing the corresponding function key.

11.4.17 `F1 Coupler Speed`

Adjustment of the maximum speed in the coupler area. It is the same for open and close.

11.4.18 `F2 Coupler Width`

The parameter coupler width shows the distance which the belt is moving in close end without moving the door panels.

11.4.19 `F3`: Statistic

F1 Counter
F2 Timer
F3 Distance
F4 Next F8 Back

This menu allows you to watch values described in the following chapters by pressing the corresponding function key.



MIDI/SUPRA V2

Operation Manual

Sheet **PM.9.005082.EN.022**
Version **-/03.10.2022**
Date **03.10.2022**
Approved **WATMZe**

11.4.20 'F1 Counter'

This counter shows the number of the driven door cycles.

11.4.21 'F2 Timer'

This counter shows the power-on time of the door electronic.

11.4.22 'F3 Distance'

This counter measures the absolute movement of the drive belt in meter, but not the coupler movement (= distance the rollers have moved).

11.4.23 'F4': Next (Statistic)

F1 Energy	
F2	
F3	
F4	F8 Back

This menu allows you to watch values described in the following chapters by pressing the corresponding function key.

11.4.24 'F1 Energy'

This counter counts the electric energy feed to the drive in KWh.

11.4.25 'F4': Next (Main Menu)

F1 Error List	
F2 Belt Position	
F3 Log Out	
F4	F8 Back

This menu allows you to watch values described in the following chapters by pressing the corresponding function key.



WITTUR

MIDI/SUPRA V2

Operation Manual

Sheet	PM.9.005082.EN.023
Version	-/03.10.2022
Date	03.10.2022
Approved	WATMZe

11.4.26 'F1 Error List'

Errors are coded with numbers or letters. Failures displayed first are occurred last. The Error List can be delete with the key 'F5' .

Possible Faults are:

- ,EE': EEprom writing or reading fault
- ,OC': Over current
- ,RS': Faulty reference switch
- ,IE': Internal software fault
- ,AP': Fault by position counter, door width > 3,5m
- ,TS': Faulty temperature sensor
- ,NE' :Encoder not connected
- ,ME': Fault by motor or encoder
- ,SS': Standstill fault, door is blocked
- ,TH': Temperature of the electronic or motor too high
- 'FE': Is set during manual change of coupler movementparameter.
- ,ES': Fault by encoder, signals out of limits
- 'BE': Electrical error during rotor angle detection, no current is flowing (motor not connected)
- 'BM': Mechanical error during rotor angle detection (door is stalled, or rotation direction is wrong -> press learn button)
- 'PS': Parameter set error

11.4.27 'F2 Belt Position'

Actual position of the belt, positive- door panels open (then it is the door panel position), negative - coupler area

11.4.28 'F3 Log Out'

By pressing F3 the communication between door drive and WPT is stopped and the WITTUR Programming Tool switches off.



WITTUR

MIDI/SUPRA V2

Operation Manual

Sheet	PM.9.005082.EN.024
Version	-/03.10.2022
Date	03.10.2022
Approved	WATMZe

12. Firmware update via SD-Card

12.1 Preparing SD Card

Use an empty micro SD Card. Copy the update file to the micro SD. It is important that the first 3 characters of the file name is named „upd“, the file will be provided by Wittur in correct condition, no need to rename. If the file is renamed and the first 3 characters are not „upd“ the update will not work.

12.2 Put the SD card to the door electronic

Disconnect door from Power, wait till all LED's are off. When all LED's are off put in the micro SD Card in the Micro SD Card slot. Switch on Dip switch S1/1, update does only work when DIP-S1/1 is on.

12.3 Execute update

After executing steps described in chapter 12.1 and 12.2, apply power to the door electronic. After short time Power LED should start flashing for around 10 seconds, update is done when Power LED stops flashing (state on).

If the update does not work the the CAN Error LED start flashing. During the update do not disconnect the board from power.

After Update is done, SD card can be removed. If SD Card stays at the door electronic, update will be not done again.

13. FPC program update via SD-Card

13.1 Preparing SD Card

Use an empty micro SD Card. Copy the update file to the micro SD. It is important that the file name is „SET_PROG.txt“, the file will be provided by Wittur in correct condition, no need to rename. If the file is renamed, update will not work.

13.2 Put the SD card to the door electronic

Disconnect door from Power, wait till all LED's are off. When all LED's are off put in the micro SD Card in the Micro SD Card slot. Switch on Dip switch S1/1, update does only work when DIP-S1/1 is on.

13.3 Execute update

After executing steps described in chapter 13.1 and 13.2, apply power to the door electronic. After short time Motor will vibrate for two times, update is done after vibrating.

After Update is done, SD card can be removed. If SD Card stays at the door electronic, update will be not done again.



WITTUR

WITTUR manufacturing locations

Product manufacturer reference can be found on the product type label.

ARGENTINIA

WITTUR S.A.
Av. Belgrano 2445
Sarandi - Pcia. de Buenos Aires, Argentina

ITALY

WITTUR S.P.A.
Via Macedonio Melloni no 12
43052 Colorno, Italy

AUSTRIA

WITTUR Austria GmbH
Sowitschstrasse 1
3270 Scheibbs, Austria

INDIA

WITTUR Elevator Components India Pvt. Ltd.
Survey nos 45/1B, 3 & 4 , Pondur Village
Sriperumbudur – 602 105
Tamil Nadu, India

BRAZIL

WITTUR LTDA
Rodovia Celso garcia Cid
1406 Cambé Parana, Brazil

SLOVAKIA

WITTUR S.R.O.
Priemyselná ulica 2747/7
963 01 Krupina, Slovakia

CHINA

WITTUR Elevator Components (Suzhou) Co. Ltd.
18 Shexing Road, FOHO Economic Development
Zone, Wujiang City, Jiangsu Province,
P.R. China 215214

SPAIN

WITTUR ELEVATOR COMPONENTS S.A.U.
Polig. Ind. Malpica, Calle E - Parcela 8
50016 Zaragoza, Spain

GERMANY

WITTUR ELECTRIC DRIVES GMBH
Offenburger Str. 3
01189 Dresden, Germany

TURKEY

WITTUR Asansör San. ve Tic. A.S.
Y Dudullu Organize - Sanayi Bolgesi n° 13
34776 Istanbul, Turkey



**YOUR GLOBAL PARTNER FOR COMPONENTS,
MODULES AND SYSTEMS IN THE ELEVATOR INDUSTRY**

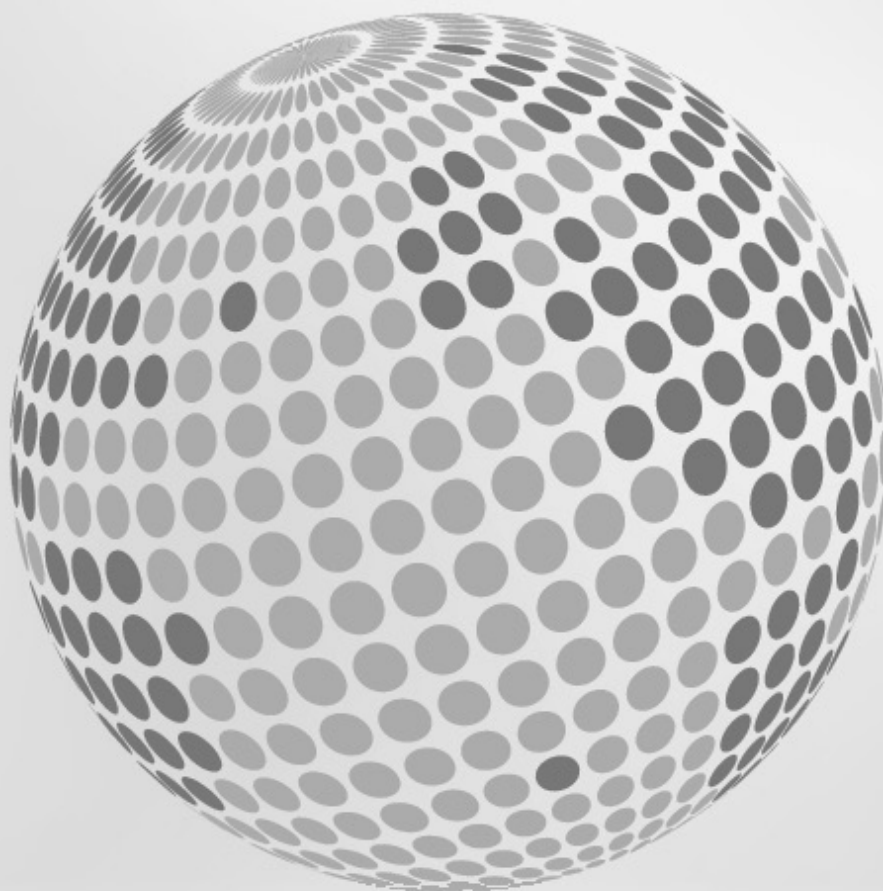

www.wittur.com



SELCOM
a WITTUR brand

Liftmaterial
a WITTUR brand

sematic
a WITTUR brand