

DOOR CONTROL DRIVE

Doorlink-100



USER MANUAL

SICOR ITALY
AN  ELEVANTIS COMPANY

sicoritaly.com



BRH004_REV19 - ENG

Preface

Thank you for choosing **ELEVANTIS's high-performance Doorlink-100 Series**. The **Doorlink-100 Series** is manufactured with high-quality components and materials and incorporate the latest microprocessor technology available.

This manual is to be used for the installation, parameter setting, troubleshooting, and daily maintenance of the AC motor drive. To guarantee safe operation of the equipment, read the following safety guidelines before connecting power to the AC motor drive. Keep this operating manual at hand and distribute to all users for reference.

To ensure the safety of operators and equipment, only qualified personnel familiar with AC motor drive are to do installation, start-up and maintenance. Always read this manual thoroughly before using **Doorlink-100** series AC Motor Drive, especially the WARNING, DANGER and CAUTION notes. Failure to comply may result in personal injury and equipment damage. If you have any questions, please contact your dealer.

Publication History

Please include the Issue Edition and the Firmware Version, both readable scanning the QR printed on the **Doorlink-100**, when contacting technical support regarding this publication.

Manual version	Issue date	Description
0,0	10.09.2025	First release

“ TABLE OF CONTENT ”

1 Safety Information and Precautions	4
1.1 Environmental Protection	4
2 Product Information	5
2.1 Receiving and Inspection	5
2.2 Features	6
2.3 Components	7
3 Mechanical Installation	8
3.1 Installation Environment	8
3.2 Diagram of installation dimensions (unit: cm)	8
4 Electrical Installation	9
4.1 Power Supply	12
4.2 Outputs: J7, J8	12
4.3 Inputs: J5	12
4.4 Motor Connector: J2	13
4.5 Encoder Connector: J3	13
4.6 CAN Connector: J8, J9	13
4.6 bis CAN Termination resistor SW2	13
4.7 Nudging Connector: J4	13
4.8 Status LED Indicator	14
5 BLE mobile app	15
6 QUICK START	20
7 Parameters	24
7.1 Commands	24
7.2 Door Configuration	24
7.3 Profile Configuration	24
7.4 Hardware Configuration	25
7.5 Functions	25
7.6 Informations	26
7.7 Door Status	27
7.8 Counters	28
7.9 Advanced Configuration	29
8 Alarms and Warnings	30
8.1 Alarms and Warnings	30

1 Safety Information and Precautions



- AC input power must be disconnected before any wiring to the AC motor drive is made.
- A charge may still remain in the DC-link capacitors with hazardous voltages, when the power is turned off.
- There are highly sensitive CMOS IC components on the printed circuit boards. These components are especially sensitive to static electricity. To prevent damage to these components, do not touch these components or the circuit boards with metal objects or your bare hands.
- Ground the Doorlink-100 by scratching the black paint on the top and on the bottom of the fixing holes, that are present on the sides of the Doorlink-100. The grounding method must comply with the local standard of the country which the drive is installed.
- **Doorlink-100 series can only be used for variable speed control of 3-phase induction and PM motors, it should NOT be applied to 1-phase motors or other purpose.**
- Doorlink-100 series is a specific drive for elevator door and other automatic door control. It should not be installed in a location that may cause personal injury.
- To prevent personal injury, please keep children and unqualified people away from the equipments.



- Do NOT connect AC main power directly to the drive's output terminals U/T1, V/T2 and W/T3.
- DO NOT use Hi-pot test for internal components. The semi-conductor used in the AC motor drive is easily damaged by high-voltage.
- A charge may still remain in the main circuit terminals with hazardous voltages, even when motor has come to stop.
- Only the qualified technicians are allowed to install, wire and maintain AC motor drive.
- Be aware of the motor that it may rotates as soon as the OPEN, CLOSE or SELFLEARNING digital inputs are active by an external ALTO, or smartphone app, DO NOT stand next to the motor.



- DO NOT install the AC motor drive in a place subjected to high temperature, direct sunlight, high humidity, excessive vibration, corrosive gases or liquids, or airborne dust or metallic particles.
- Follow the installation instructions when installing the AC motor drive. Failure to comply may result in fire, explosion or electric shock.
- When the motor cable between the AC motor drive and motor is too long, the layer insulation of the motor may be damaged.
- The rated voltage for the AC motor drive must be $\leq 240V$ and the mains supply current capacity must be $\leq 1000A$ RMS.
- If the AC motor drive is stored in no charge condition for more than 3 months, the ambient temperature should not be higher than 30 °C. Storage longer than one year is not recommended, it could result in the degradation of the electrolytic capacitors.
- Pay attention to the following when transporting and installing this package (including wooden crate, wood stave and carton box)
 1. If you need to sterilize, deworm the wooden crate or carton box, please do not use steamed smoking sterilization or you will damage the VFD (Variable Frequency Device).
 2. Please use other ways to sterilize or deworm.
 3. You may use high temperature to sterilize or deworm. Leave the packaging materials in an environment of over 56 for 30 minutes.
 4. It is strictly forbidden to use steamed smoking sterilization. The warranty does not covered VFD (Variable Frequency Device) damaged by steamed smoking sterilization.

1.1 Environmental Protection



Reuse

- Some components of the product can be reused due to high metal content. Dismantle the product into individual components to improve the metal recycling efficiency. Electrical and electronic components contain metal materials that can also be recycled through a specific separation process.



Disposal

- Discard components that cannot be degraded and recycled as industrial wastes.

2 Product Information

2.1 Receiving and Inspection

The AC motor drive should be kept in the shipping carton or crate before installation. In order to retain the warranty coverage, the AC motor drive should be stored properly when it is not to be used for an extended period of time. Storage conditions are:



- Store in a clean and dry location free from direct sunlight or corrosive fumes.
- Store within an ambient temperature range of -20 °C to +50 °C.
- Store within a relative humidity range of 0% to 90% and non-condensing environment.
- Store within an air pressure range of 86 kPa to 106kPa.
- DO NOT place on the ground directly. It should be stored properly. Moreover, if the surrounding environment is humid, you should put exsiccate gel in the package.
- DO NOT store in an area with rapid changes in temperature. It may cause condensation and frost.
- If the AC motor drive is stored for more than 3 months, the temperature should not be higher than 30 °C. Storage longer than one year is not recommended, it could result in the degradation of the electrolytic capacitors.
- When the AC motor drive is not used for longer time after installation on building sites or places with humidity and dust, it's best to move the AC motor drive to an environment as stated above.

This Doorlink motor drive has gone through rigorous quality control tests at the factory before shipment. After receiving the AC motor drive, please check for the following:

- Check to make sure that the package includes an AC motor drive, the User Manual/Quick Start.
- Inspect the unit to assure it was not damaged during shipment.
- Make sure that the part number indicated on the nameplate corresponds with the part number of your order.

NOTE: If the nameplate information does not correspond with your purchase order or if there are any problems, please contact your local distributor.

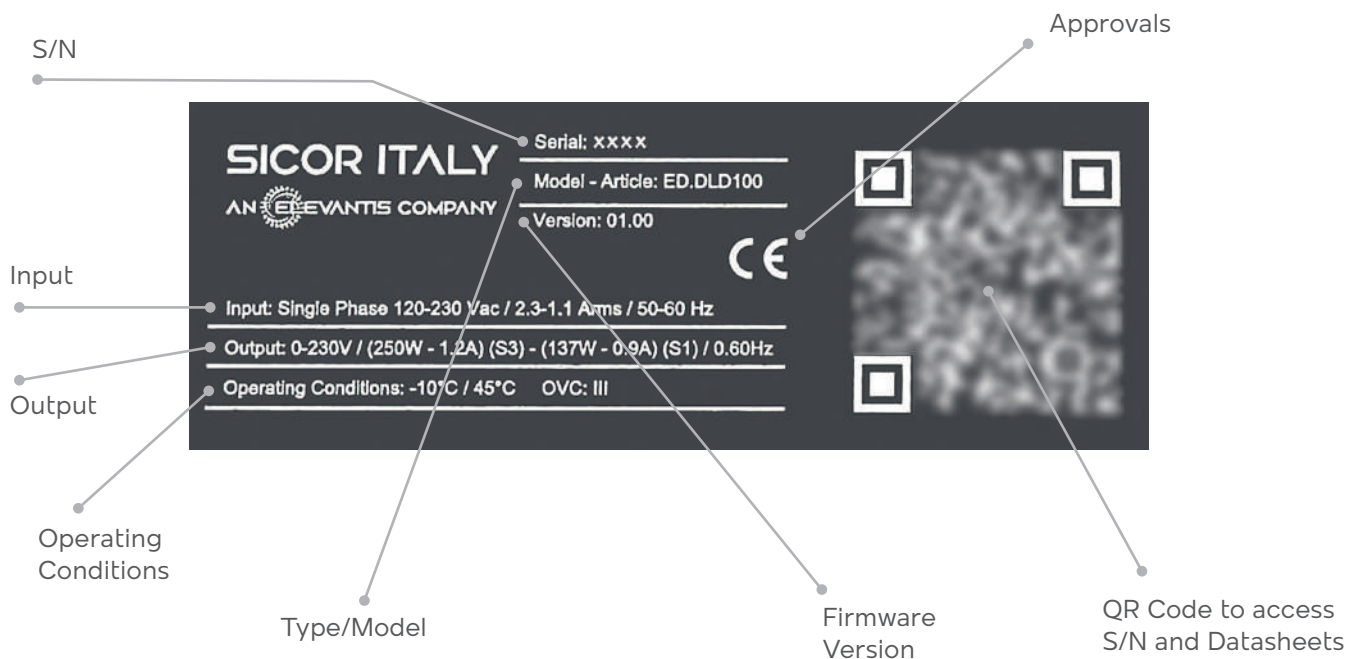

2 Product Information

2.2 Features

ELEVANTIS Doorlink-100 series elevator door control drive is an intelligent drive with key features including modular design for easy removal and installation of terminal blocks, built-in mobile app that provides quick control of operations and commissioning.

This drive offers sophisticated door control modes for opening and closing doors. Distance control is commanded by a proprietary encoder to obtain accurate position and speed.

ELEVANTIS Doorlink-100 series elevator door control drives are a complete solution integrating modern and innovative algorithm and hardware solutions.

- The door width is automatically determined and recorded in the elevator related parameters.
- Continuous door opening and closing curve reduces vibration.
- Block detection, even if the safety device fails, Doorlink-100 can reopen the doors based on the current detection.
- Precise torque detection, keeps the door open/closed.
- Motor type: PM with proprietary encoder and interface protocol.
 - **SDM085** Sicor italy PM motor with proprietary encoder and interface protocoll
 - **SDM200**: Sicor italy PM motor with proprietary encoder and interface protocoll
 - **PM10** Fermator.
- Supports IM asynchronous motors.
- Motor control: FOC-CL for PM and V/F + slip compensation for induction motor (IM).
- Communication interfaces: CAN-OPEN / wireless BLE / Digital I/O / SmartPhone App.

GENERAL INPUT SPECIFICATIONS	
AC input voltage range	Single phase: 120 - 230 Vac
AC input frequency supply	50/60Hz
Stand by power	5.5W
GENERAL INPUT SPECIFICATIONS	
Output carrier frequency	10 KHz
Output frequency range	0.5...60Hz
Output power	250W (S3) - 137W (S1)
3φ PM MOTOR	
Control mode	FOC + PG
Voltage supply	110V
Nominal power	96 W
Nominal torque	1.5N.m
3φ INDUCTION MOTOR	
Control mode	V/F + slip compensation
Voltage supply	230V
Nominal power	150 W
Nominal torque	1.57N.m
INPUTS	
Multi - Function Input Signal	8 + (1)
Voltage	15Vdc to 48Vdc
Current	<10mA
OUTPUTS	
Multi - Function Output Signal	6 (N.C / N.O.)
Voltage	Up to 48Vdc, Up to 120Vac
Current	<80mA
WIRELESS INTERFACE	
Dedicated wireless (BLE) connection with SmartApp	
WIRE INTERFACE	
1 x CAN / CAN-open 417	
PERFORMANCE	
Open Speed	200...700 mm/s
Close speed	150...400 mm/s
Safety force	60...150N adjustable
Size	280 x 116 x 40
Operative range	-10°C ÷ 45°C
Environment sensing & protection	Temperature Pressure
Certification	UL, CE
Enclosure rating	IP20

Operating mode

S3: on time (90 seconds) – 70% off time (210 seconds)

2 Product Information

2.3 Components

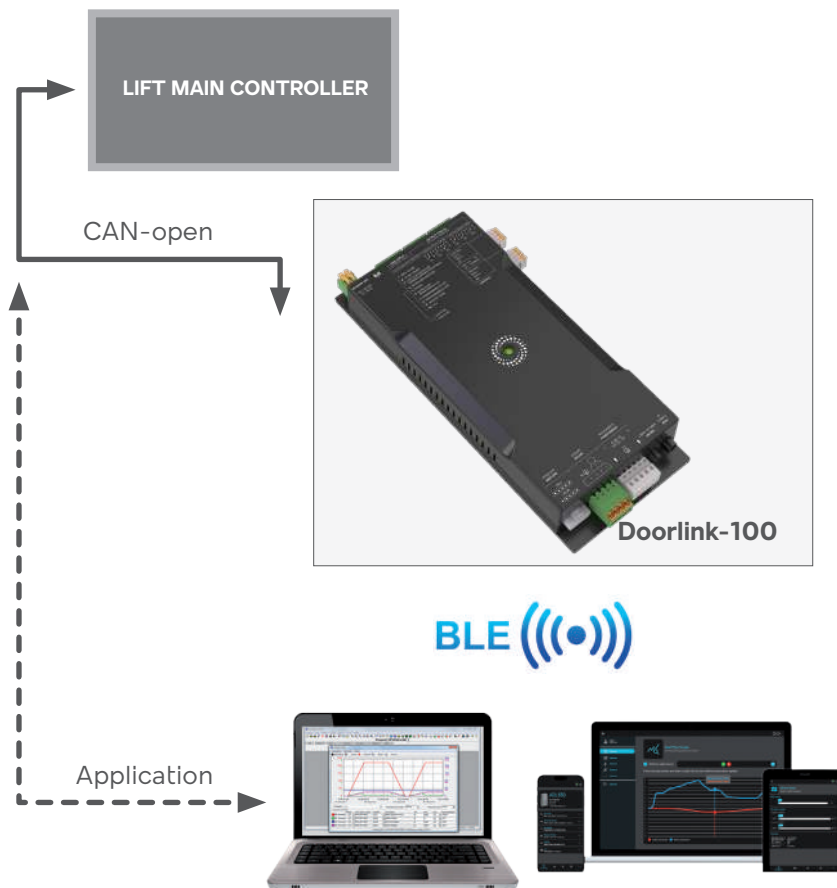

Functions

- Open/close with speed/ramp selection/adjust
- S-shape position profile
- Final speed adjustable
- Permanent torque adjustable: during full open and closed separately
- Moving-mass estimation
- Motor temperature estimation
- Enviromental condition: temperature/floor level
- Self-adjustment - door learning
- Rotation selection
- Memory & alarms
- Motor set-up: Phasing - Identification

3 Mechanical Installation

3.1 Installation Environment

Item	Requirements
Temperature	- 10°C to +45°C
Altitude	Below 2000 m
Enclosure	Open type - IP20
Overvoltage	Category III
Pollution	Degree 3

3.2 Diagram of Installation Dimensions (mm/inch)

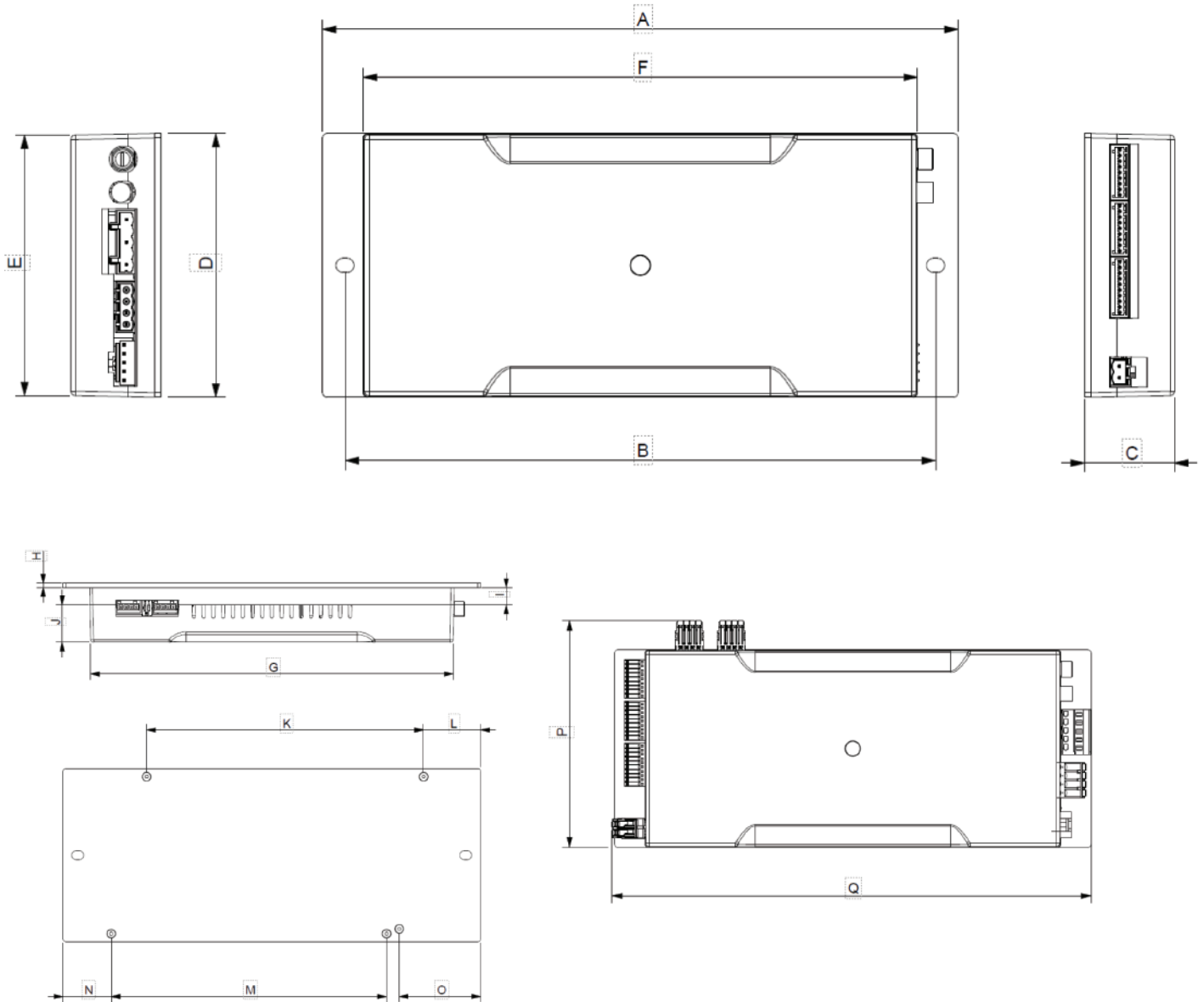

	A	B	C	D	E	F	G	H	I	J	K	L	M	N	O	P	Q
mm	282	262	40	117	115.7	246	244.7	3	11,6	25,4	187	38,5	185,9	32,6	55	134,5	283,5
inch	11 7/64	10 5/16	1 37/64	4 39/64	4 9/16	9 11/16	9 41/64	1/8	29/64	1	7 23/64	1 33/64	7 5/16	1 9/32	2 11/64	5 19/64	11 5/32

4 Electrical Installation

Warning



- Do not power on the device before wiring is completed. Failure to comply may result in electrical shock.
- Never connect the controller output terminals U, V, and W to a three-phase power supply. Failure to comply may result in physical injury or fire.
- Never connect the motor terminals U, V, and W to a mains power supply. Failure to comply may result in physical injury or fire.



- Wiring must be carried out by electrical engineering specialists only.
- Ensure that the input voltage of the controller is within the allowable range. Failure to comply may result in product faults.
- Connect an electromagnetic contactor between the input power supply and the main circuit of the controller, to form a structure that can cut off the power supply on the power side of the controller. Otherwise, continuous large current upon controller faults may cause fire.
- Insulate the connection part of power supply terminals during wiring of the power supply and main circuit. Failure to comply may result in electric shock.
- Ground the entire system. Failure to comply may result in injury or accidents.
- After power-off, wait at least 15 minutes before further wiring operations because residual voltage exists after power-off. Failure to comply may result in electric shock.

Caution



- Never place cables under heavy objects or drag cables vigorously. Failure to comply may result in cable damage and electric shock.
- Never allow metal debris, screws, or liquid to enter the controller during wiring. Failure to comply will result in insulation failure or short circuit.



- Protect external wiring, branches, and short circuits according to local regulations.
- Ensure compliance with cable diameter and withstand voltage requirements of the power cable and control power incoming line.
- Strictly follow the specified torque when installing the screws.
- For each peripheral device, read its user guide, fully observe its precautions, and use it properly.
- Wire devices properly. Improper wiring may cause damage to the controller and motor.

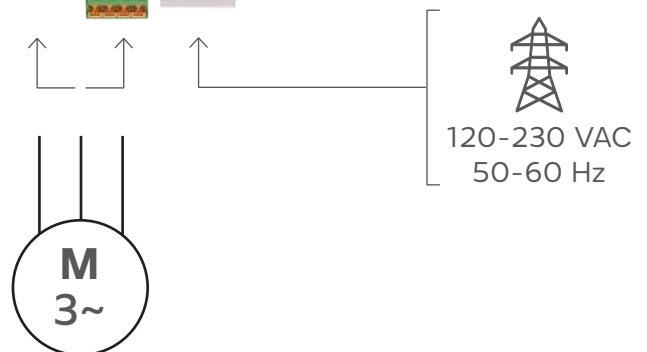
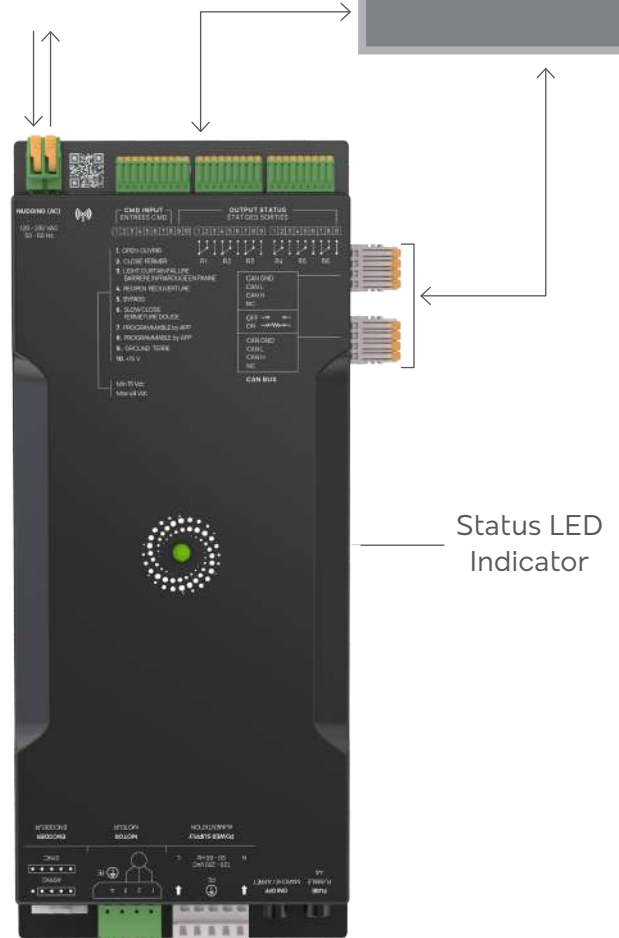

4 Electrical Installation



Category	Terminal Definition	Terminal Name	Terminal Description
Power Supply	J1-1	N	Main supply of 120-230 V AC.
	J1-2	GROUND	
	J1-3	L	
Motor	J2-1	Phase W	Output to the 3 phase motor varying the voltage and frequency to control speed and torque.
	J2-2	Phase V	
	J2-3	Phase U	
	J2-4	GROUND	
Encoder	J3	PM/ASINC	An incremental quadrature pulse encoder and RS485 serial line are connected to this input. The purpose of the encoder, which is situated inside the motor, is to inform the control of the exact position and speed of doors.
Nudging	J4-1	120-230 VAC	
	J4-2	COMMON	
Digital Input The circuit can work with external voltage inputs or internal voltage input (voltage free contact).	J5-1	OPEN	Is a signal that orders the door to open. With an external voltage input the tension to apply could be from 15 V DC to 48 V DC between this input and common. With an internal voltage input the tension applied is 15 V DC between this input and Out +15 V.
	J5-2	CLOSE	This signal is used for ordering to close the door. With an external voltage input the tension to apply could be from 15 V DC to 48 V DC between this input and common. With an internal voltage input the tension applied is 15 V DC between this input and Out +15 V.
	J5-3	CURTAIN FAULT	This input is used to detect a Failure from the light curtain. It generates alarm 3 "Light Curtain fault".
	J5-4	REOPEN	This signal is used for installing the cabin door switch, an external barrier or other devices. In order to active this signal, connect the re-open input with the +15 V. Use voltage free contacts. The reopening signal has priority over the closing signal.
	J5-5	BY-PASS	This signal is used to connect an external security switch to detect door closed position.
	J5-6	SLOW CLOSE	This signal is used for ordering to close the door slowly. Also see 303 "Slow open" for operation with Open input The slow signal has priority over the control signals and the photocell
	J5-7	SELF-LEARNING	This signal is used to start the self learning procedure. For details see the dedicated session.
	J5-8	SPARE 1	For future uses.
	J5-9	GND	Is the reference used for the opening and closing signal.
	J5-10	+15V	Isolated 15 Volts output available to control the door through a voltage free contact. Features are: a) This supply must only be used for this purpose. b) This contact must be isolated from any other power supply.

4. Electrical Installation

Category	Terminal Definition	Terminal Name	Terminal Description
Outputs Output relays have been provided to give continuous information to the main lift controller concerning the status of the doors.	J6-1	OPENED (N.C.)	This event is present when the doors are fully open.
	J6-2	COMMON	
	J6-3	OPENED (N.O.)	
	J6-4	CLOSED (N.C.)	This event is present when the doors are fully closed and locked.
	J6-5	COMMON	
	J6-6	CLOSED (N.O.)	
	J6-7	REOPEN (N.C.)	This event is present when the REOPEN input is active and during reopen action after obstruction in master mode
	J6-8	COMMON	
	J6-9	REOPEN (N.O.)	
	J7-1	OBSTRUCTION (N.C.)	This event is present when an obstacle is detected that stops the doors from closing or opening. The signal will reset when the doors reach the opened or closed position.
	J7-2	COMMON	
	J7-3	OBSTRUCTION (N.O.)	
	J7-4	CURTAIN (N.C.)	Relay activated when a failure occurs on the light curtain.
	J7-5	COMMON	
	J7-6	CURTAIN (N.O.)	
J7-7	TEMPERROR (N.C.)	This event is present when the VF temperature or motor temperature exceeds the safety limit. When this output is activated, the maneuver must give the order to the cabin to go to the next floor, open the door to let out the passengers and stop applying tension to the motor.	
J7-8	COMMON		
J7-9	TEMPERROR (N.O.)		
Communication	J8-1	NC	Isolated type. Communication baud rate: 125kbps, 250kbps, 500kbps, 1Mbps. This allows the communication with the Lift Main Controller.
	J8-2	CAN-H	
	J8-3	CAN-L	
	J8-4	CAN GROUNG	
	J9-1	NC	
	J9-2	CAN-H	
	J9-3	CAN-L	
	J9-4	CAN GROUNG	

On Board Connector	Mated Connector	Wire Details	Socket Model	Plug Model	Pin Model
J1	J1C	rated 300V, 15A, UG=B or C or D, 105°C, FW=2, Cu only, 12-22 AWG	450803-ZK01 721-435/001-000	450603-ZK01 721-105/026-000	spring type connector
J2	J2C	rated 300V, 10A, UG=D, FW=2, 105°C, AWG 30-12	MSTBA 2.5-4-G-5.08	XPC 2,5/ 4-ST-5,08	spring type connector
			MC-PA5.08H04-0002	MC-RJ5.08H04P-0001	
J3	JC3	rated 3A, 250Vac/dc, 130°C	B5PS-VH	VHR-5N or VHR-5M	factory provided with wiring leads for connection in the field
J4	JC4	rated 300V, 5A, UG=D, FW=2, 105°C, 12-24 AWG	MC-PA5.08H02-0002 MSTBA 2,5/ 2-G-5,08 2EHDR-02P	MC-RJ5.08H02P-0001 FKC 2,5/ 2-ST-5,08 2ESS-02P	spring type connector
J5	JC5	rated 150V, 4A, UG=B, CU only, FW=2, 105°C, AWG 20-28	MC 0,5/10-G-2,5 ECH250R-10P	FK-MC0.5 ESC250V-10P	spring type connector
J6 - J7	JC6 - JC7	rated 150V, 4A, UG=B, CU only, FW=2, 105°C, AWG 20-28	MC 0,5/9-G-2,5 ECH250R-9P	FK-MC0.5 ESC250V-9P	spring type connector
J8 - J9	JC8 - JC9	rated 300V, 10A UG=B/D, 120°C, FW=2, AGW 24-16	734-164 0135-4104	2734-1104/327-000 0134-4104	spring type connector

4. Electrical Installation

4.1 Power Supply: J1

The circuit has been designed to operate with a main supply of 120-230 Vac, 50/60 Hz).

Doorlink-100 incorporates a soft-start system to control the bulk capacitors charge and prevent short circuits.

Note: It is important that the Door Operator Module has a good earth connection

Power Supply Connection

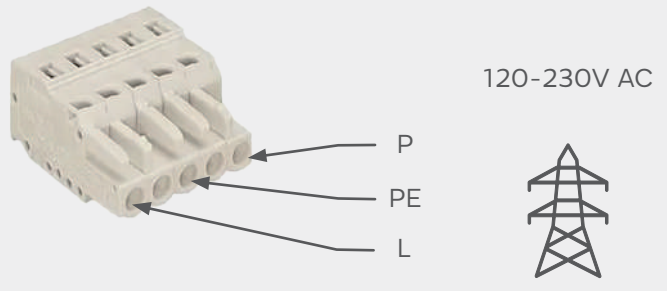

4.2 Outputs: J6, J7

Output relays have been provided to give continuous information to the main lift controller concerning the status of the doors.

Relay Default Configuration

R1	OPENED
R2	CLOSED
R3	REOPEN
R4	OBSTRUCTION
R5	LIGHT CURTAIN FAULT
R6	OVERTEMP

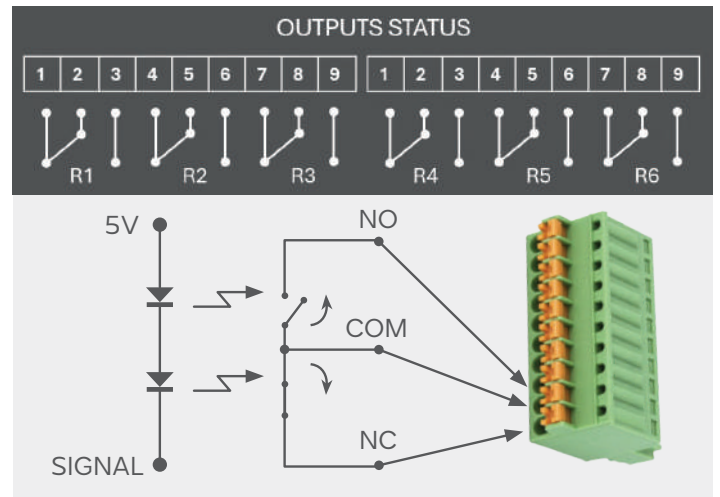

4.3 Inputs: J5

The circuit can work with external voltage inputs or internal voltage input (voltage free contact).

CDM INPUTS									
1	2	3	4	5	6	7	8	9	10

1	OPEN	Min 15 Vdc Max 48 Vdc
2	CLOSE	
3	CURTAIN FAULT	
4	REOPEN	
5	BYPASS	
6	SLOW CLOSE	
7	SELF LEARNING	
8	SPARE 1	
9	GND	
10	+15 V	

Internal Voltage Input

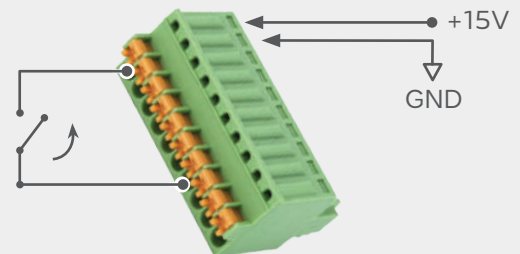

External Voltage Input

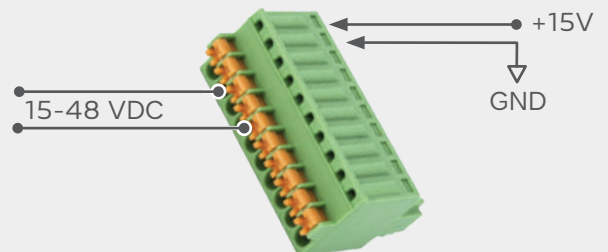

4. Electrical Installation

4.4 Motor Connector: J2

Motor Connector

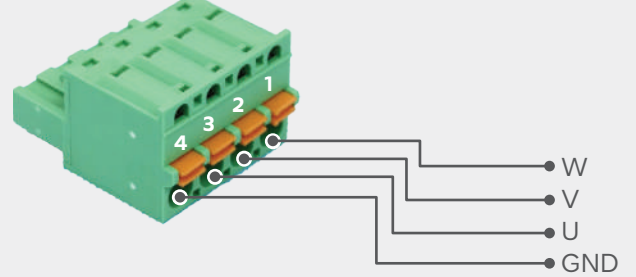

4.5 Encoder Connector: J3

Encoder Connector

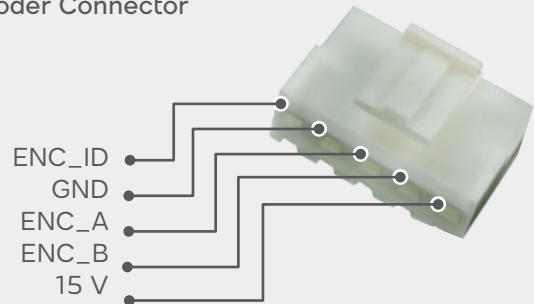

4.6 CAN Connector: J8, J9

Can Connector

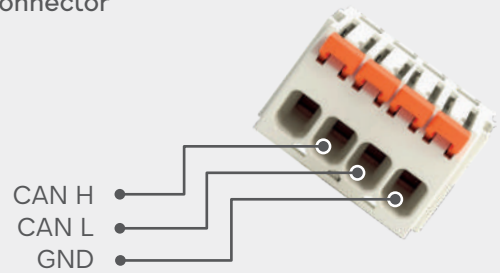

4.6 bis CAN Termination resistor SW2

Can Termination resistor



ON - Terminated
OFF - Not terminated





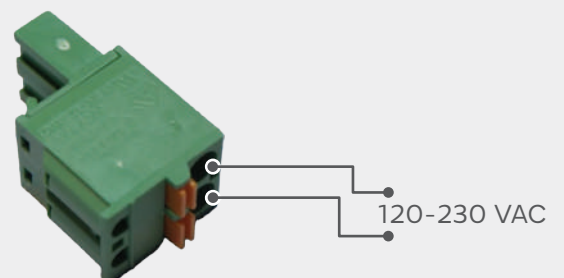



4.7 Nudging Connector: J4

Nudging Connector



4. Electrical Installation

4.8 Status LED Indicator

Indicator	State	description
	Alternating blue-white flashing	Waiting for commands and connected through the BLE
	White flashing	Waiting for commands
	Alternating blue-red flashing	In a fault status and connected through the BLE
	Red flashing	In a fault status
	Alternating blue-green flashing	Waiting and connected through the BLE
	Green flashing	Waiting
	Alternating green-red flashing	Firmware update
	White - green flashing	Self Learning
	Off	Doorlink turned off

5. BLE mobile app

The product supports interaction through the mobile app, which makes commissioning simple and easy and resolves inconvenience in operating the door operator.

The mobile app supports more operations on the door operator drive than the panel does.

The operations include parameter modification, working status monitoring, and running control. See the following description for examples of the basic app functions in door operator drive commissioning.

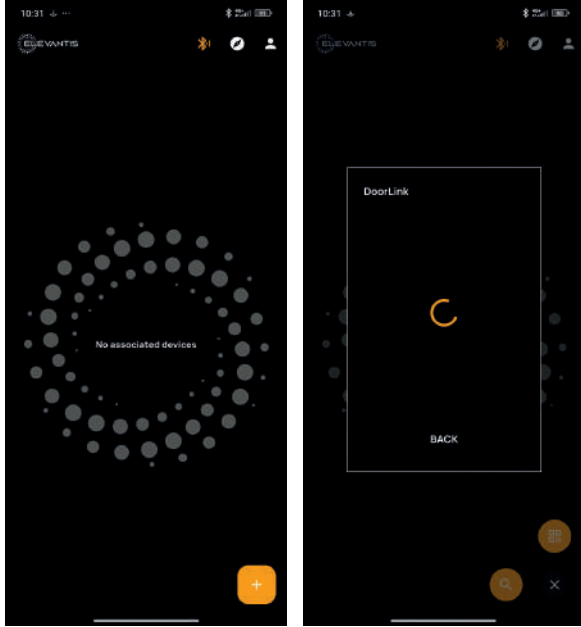

Device Connection:

This is the first page that appears when the mobile app is opened. The list of local Doorlink device is shown. Select the device to be connected from the BLE list devices found.

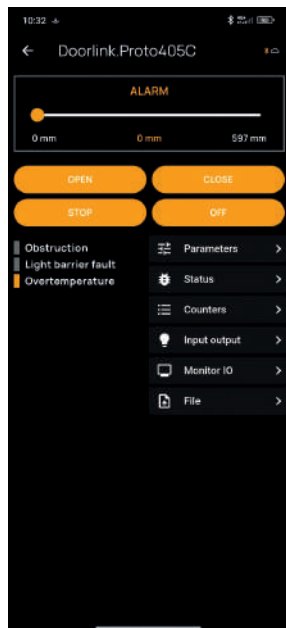

Menu:

The next two pages show the menu of pages that can be accessed.

- Parameters
- Status
- Counters
- Input Output
- Monitor IO
- File

In the same page it is possible to send OPEN/CLOSE command.

The command STOP, stop the door in the actual position. Instead the command OFF cuts engine torque.

Status information of the door are present.

The status door information are:

- Door position
- Door alarms
- Door warnings

5. BLE mobile app

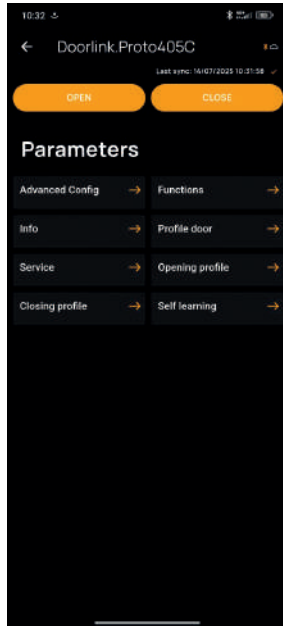

Parameters Page:

In this page is possible to see and modify all the parameters allowed by user.

The parameters are grouped by sections.

- Advanced Config
- Functions
- Info
- Profile door
- Service
- Opening profile
- Closing profile
- Self learning

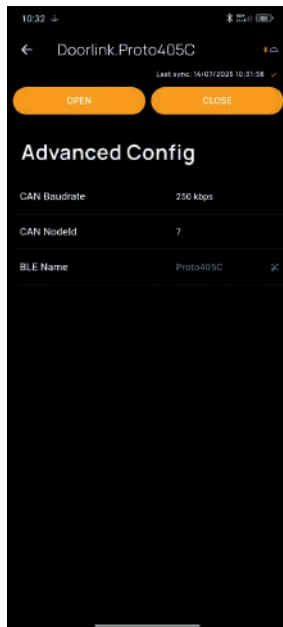

Parameters->Advanced Config

Here is possible modify the following parameters:

- CAN baudrate
- CAN nodeId
- BLE Name

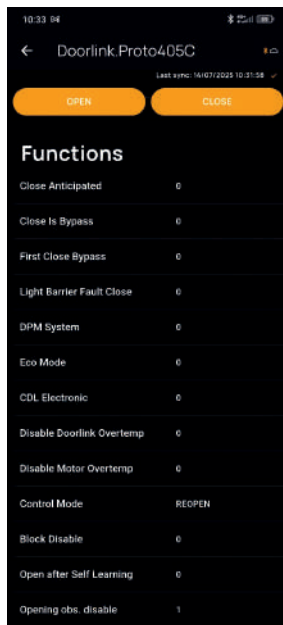
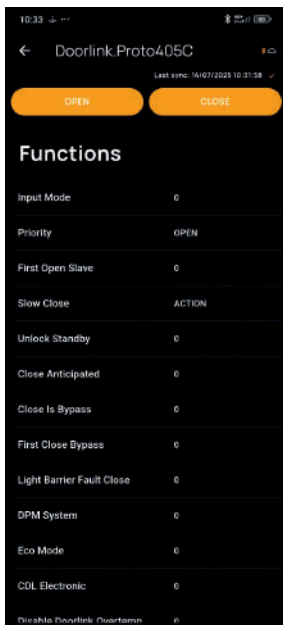

Parameters->Functions

List of the functions that can be configured.

5. BLE mobile app

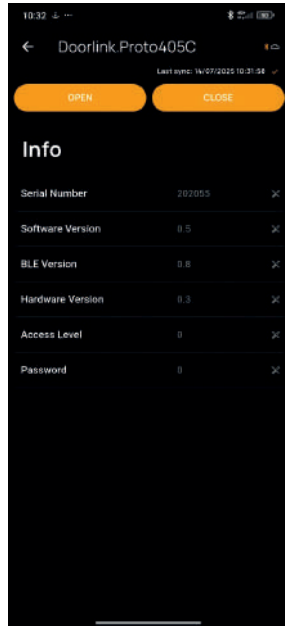

Parameters->Info

Information on the Doorlink device, versions and serial number



Parameters->Profile Door

In this page is possible modify all the parameters related to the Door profile



Parameters->Opening Profile

In this page is possible modify all the parameters related to the Opening profile.

Most of parameters are calculated in the learning phase by choosing the parameter either through the list or directly from the graph (fine adjustment).

5. BLE mobile app



Parameters->Closing Profile

In this page is possible modify all the parameters related to the Closing profile.

Most of parameters are calculated in the learning phase but choosing the parameter trough the list or directly from the graph is possible a fine adjustment.

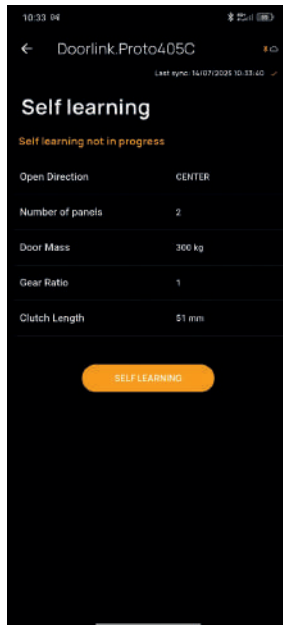

Parameters->Self Learning

The Mass and Clutch Length parameters should be calculated in the learning phase. In some doors configurations is not possible estimate all of them and in this page is possible to give them a value.

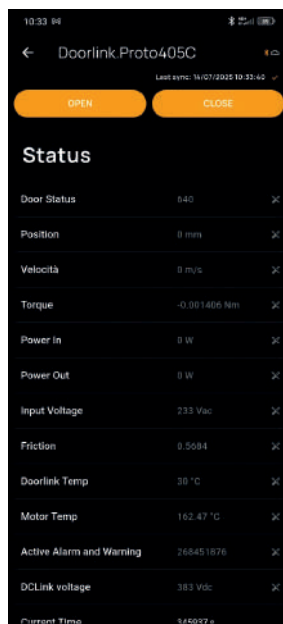

Status

Show the main information status of the door

5. BLE mobile app

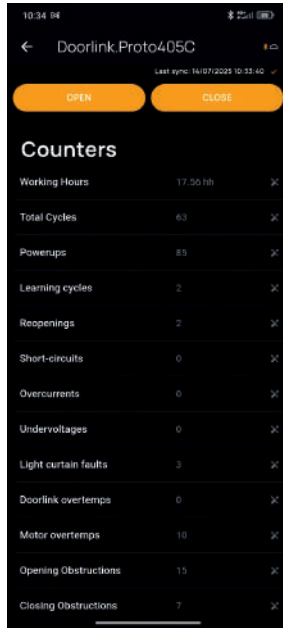

Counters

Display cumulative counters of events and total working hours

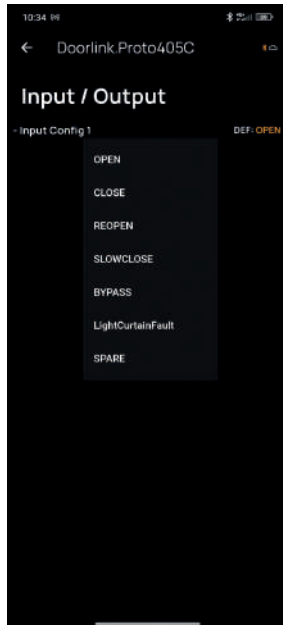
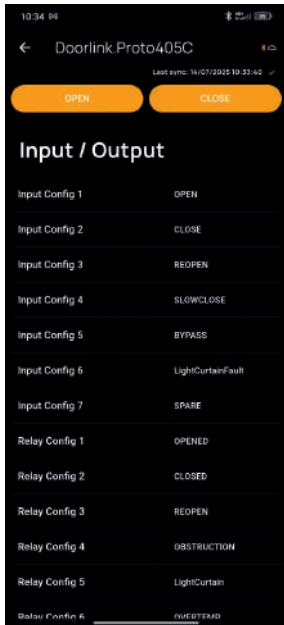

Input/Output

Select the function for each input and relay

6. Quick Start

Before executing the self-learning procedure check the correct installation of the mechanical structure without any obstruction on the door movement.

Hereafter the procedure to start-up the operation with the Doorlink using the Elevantis App.

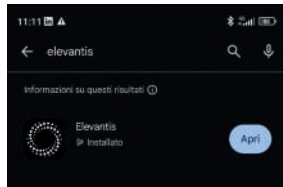

App installation:

Install the Elevantis App. The Elevantis App is available on Android and iOS and can be downloaded from both Google PlayStore and Apple Store

- Scan the QR code to download and install the APP
- Follow the registration steps

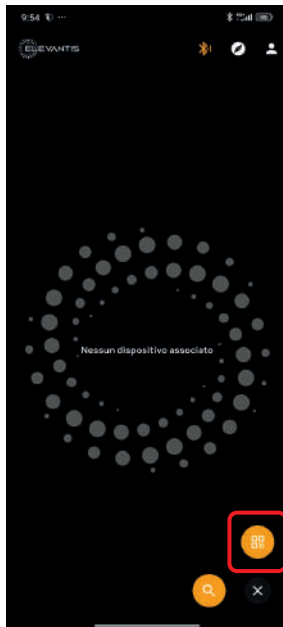

First start:

Open the Elevantis App and check which Doorlink devices are present. If none is detected or already associated, then scan the QR code on the DoorLink installed inside the Elevantis door system tapping the highlighted icon.

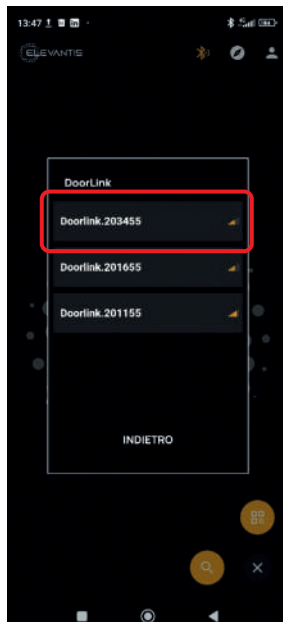

QRcode:

Scan QRcode located on the DoorLink device and pair the Doorlink with the app selecting the right S/N

After pairing, the Doorlink name should be changed in order to simplify future recognition

6. Quick Start

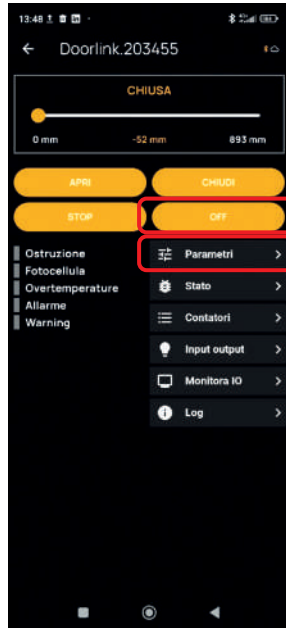

Main page menu:

The menu page includes different information's like:

- Doorlink device now connected.
- Status door position with a line bar
- 4 main button commands
- Status information of the door, if present.
- 6 sub menus
 - Parameters
 - Status
 - Counters
 - Input Output
 - Monitor IO
 - Log file

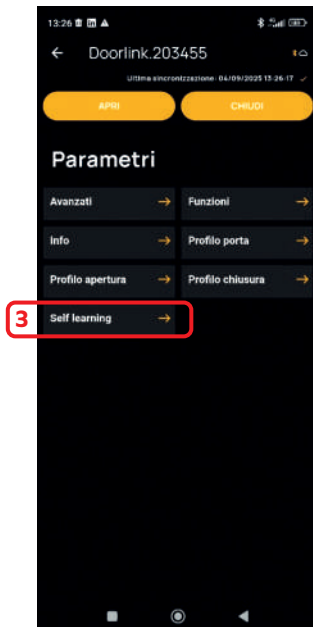

Self learning procedure:

To start the Self-learning procedure is necessary:

1. Tap OFF
2. Select the Parameters sub menu
3. Select Self-learning

If the Doorlink is connected to the lift controller it is required to activate it in "inspection operation" mode, before starting the procedure.

It's recommended to execute the Self-learning procedure with a coupled door (cabinet + floor) with the heaviest case mettere immagine

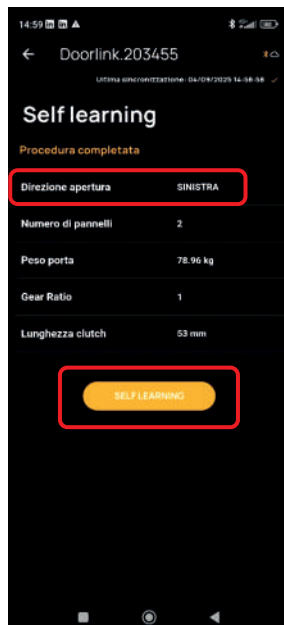
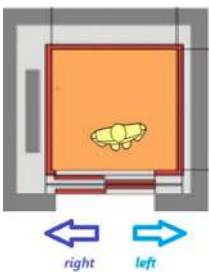

Self-learning menu:

The page includes some default configuration parameters:

- Door opening direction.
 - LEFT
 - RIGTH
 - CENTRAL
- Numbers panel
- Total moving mass
- Gear ratio
- Clutch length

All the parameters can be changed by the user.

The *Door opening direction* should be changed according with the installation with the assumption that for example the LEFT open direction is when the user is inside the cabin.

The *Total door mass* is estimated during self learning procedure.

To start the Self-learning procedure, press the relative button.

6. Quick Start

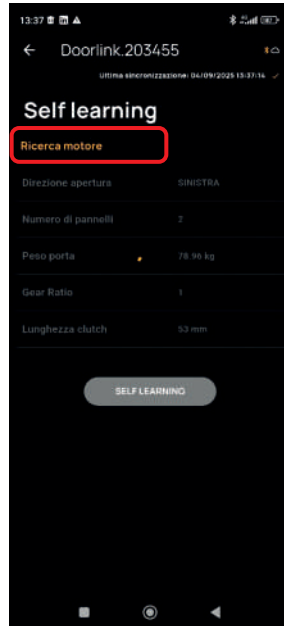

The self-learning procedure is composed by different phases where the doors open & close different times performing some specific movements necessary to identify:

- Motor type
- Motor phasing only for PM motor
- Stator resistance estimation
- Movement length
- Clutch forces
- Moving mass

The procedure progress is highlighted in the menu.

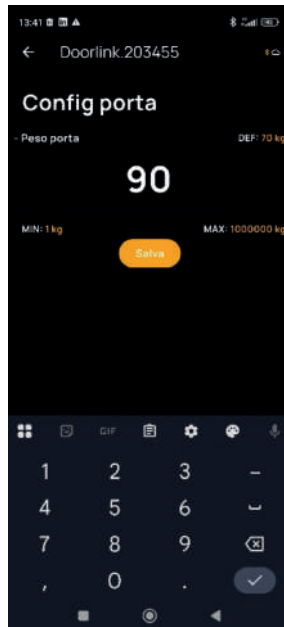

When the Self-learning is completed, the App wait a user confirmation to save the detected values within 90sec.

All detected parameters can be manually changed by the operator

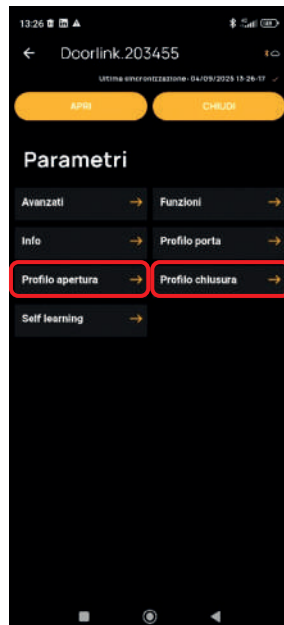
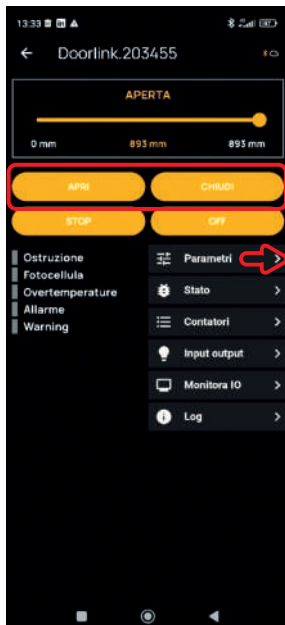

After the user confirmation of the parameters the self-learning procedure is completed and it's possible to come back to the main menu. Now in the main Menu it's possible to send OPEN/CLOSE command with the specific button.

It's also possible to customize the open/close speed profile.

6. Quick Start

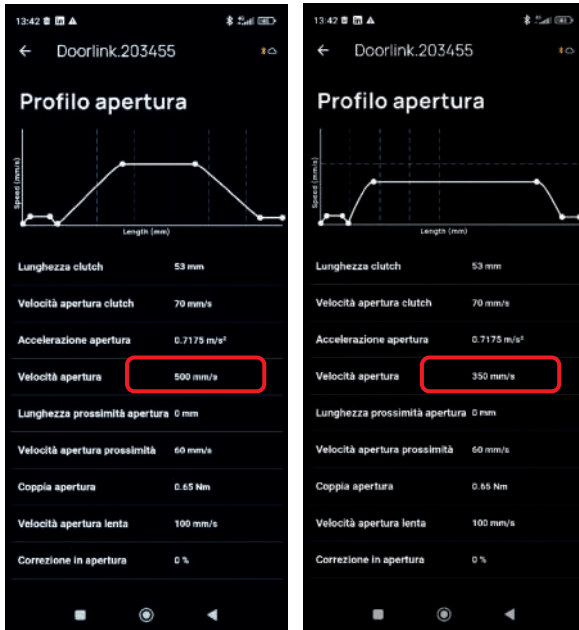

Inside the Open speed profile, it's possible to tune any parameters. All detected parameters can be manually changed by the operator. By selecting any parameter you want to change in the graph, the segment is highlighted.

Self-learning without using the APP user interface is still possible with some constraints ⁽¹⁾; a "Self-learning" selection has been configured to the digital inputs #7. Bridge J5-7 Self Learning with J5-10 (+15V).

The procedure is:

1. If the Doorlink is connected to the lift controller it is required to activate it in "inspection operation" mode, before starting the procedure.
2. Turn on the Doorlink and activate the digital #7 without any other commands (open/close etc...)
When the Doorlink is turned on, if the digital input #7 is active (connected to Vcc) and the other digital commands are not active (Open/Close/Reopen), the procedure is activated.
3. Within 10s you must deactivate the digital input #7, then activate it again and keep it active for all the self-learning session, otherwise the automatic self-learning mode is terminated and the DoorLink remains ready to receive commands
4. Start the Self-Learning procedure as described above. The default settings for Open Direction and Number of Panels are used; there's no way to adjust them without the user interface after the procedure led come back to green flashing.
5. If the direction is not detected and the procedure stops), the LED will blink white and green alternatively.
Within the timeout of 90s, you must raise the digital inputs corresponding to the position:
 - i. if it is near to the closed position, activate digital Close input command. Bridge J5-2 with J5-10
 - ii. if it is near to the open position, activate digital Open input command. Bridge J5-1 with J5-10This will continue the sequence.
Remember to lower again the open or close input as soon as the sequence restarts if you do not want the door to move at the end of the sequence.
6. At the end of the Self-learning procedure, you are not asked to confirm the clutch, mass or length within the timeout of 90s; the estimated ones are used, and the profile is calculated accordingly and then the parameters are saved.
7. The procedure ends and the Doorlink is ready to handle commands using the digital inputs.

If there are errors during Self-Learning, the procedure is interrupted and Doorlink will no longer manage the door. Nothing is saved; to try again, you must turn off the board and repeat the sequence.

(1) Using Self-commissioning without the smart-APP the moving mass estimated can not been changed, and so the max Kinetic Energy and/or max close/open force may be not guaranteed.

7. Parameters

The DoorLink-100 controller is configurable through a set of parameters, most of which are accessible from the mobile application. The following table lists all the configurable parameters, with a brief description.

7.1 Commands

N°	Range	Type	Default	Name	Unit	Description
1	0~3	ENUM	0	Door Command		Through this parameter is possible to set commands to the door. In particular: 0: OFF 1: OPEN 2: CLOSE 3: STOP
2	0~1	ENUM	0	Self Learning		0: OFF Self learning is not being executed 1: ON Self learning procedure in execution. Command can be entered only when the door is in standby. When procedure is complete, returns to OFF

7.2 Door Configuration

N°	Range	Type	Default	Name	Unit	Description
3	0~2	ENUM	0	Open Direction		Open Direction: 0: LEFT 1: RIGHT 2: CENTER
4	1~8	Unit16	2	Number of panels		Number of panels: Valid combinations are: LEFT/RIGHT 1 2 3 4 CENTER 2 4 6 8
5	1~10 ⁵	Float	70	Door Mass	[kg]	Door Mass
7	0.001~1000	Float	1	Gear Ratio		Gear Ratio: If the operator uses a pulley, this is the ratio to get the correct linear displacement corresponding to rotational movement of the motor shaft.

7.3 Profile Configuration

N°	Range	Type	Default	Name	Unit	Description
100	-100~100	Float	40	Opening Correction	[%]	Adjust arrival position. Increase if the door arrives too early, decrease if it arrives too fast.
101	0.01~900	Unit16	40	Close Initial Speed	[mm/s]	Speed before closing the door.
102	0.01~900	Float	40	Open Proximity Speed	[mm/s]	Speed near opening.
103	-100~100	Float	40	Closing Correction	[%]	Adjust arrival position. Increase if the door arrives too early, decrease if it arrives too fast.
104	0.01~900	Float	40	Open Clutch Speed	[mm/s]	Applied when moving the clutch in opening direction.
105	0.01~900	Float	40	Close Clutch Speed	[mm/s]	Applied when moving the clutch in closing direction.
106	0.01~900	Float	120	Open Speed	[mm/s]	Reached when performing a complete opening.
107	0.01~900	Float	120	Close Speed	[mm/s]	Reached when performing a complete closing.
108	0.0001~1000	Float	0,05	Open Acceleration	[m/s ²]	Reached when performing a complete opening.
109	0.0001~1000	Float	0,05	Close Acceleration	[m/s ²]	Reached when performing a complete closing.
112	0.001~10 ⁵	Float	0,01	Open Length	[mm]	Length of movement from panels closed with clutch disengaged to completely open.
114	0~10 ⁵	Float	20	Close Initial Length	[mm]	Distance to apply the initial speed 101.
115	0~10 ⁵	Float	20	Open Proximity Length	[mm]	Distance to apply the proximity speed 102.
116	0~10 ⁵	Float	20	Slow Block Length	[mm]	Distance of slow speed movement at previous closing obstruction.
117	0~10 ⁵	Float	20	Clutch Length	[mm]	Distance from door completely closed to clutch released.
118	0.01~3	Float	0,4	Max Open Torque	[Nm]	Limit torque applied during acceleration on opening movement.
119	0.01~3	Float	0,3	Max Close Torque	[Nm]	Limit torque applied during acceleration on closing movement.
120	0.01~3	Float	0,3	Hold Torque	[Nm]	Applied when door is stopped.
121	0.01~3	Float	0,3	Opened Torque	[Nm]	Applied when door is opened.
122	0.01~3	Float	0,3	Closed Torque	[Nm]	Applied when door is closed.
123	0.01~900	Float	0,3	Open Slow Speed	[mm/s]	Applied during slow open movement, if Slow Open parameter is Command.
124	0.01~900	Float	0,3	Close Slow Speed	[mm/s]	Applied during slow close or nudging movement

7. Parameters

7.4 Hardware Configuration

N°	Range	Type	Default	Name	Unit	Description
200	0~7	enum	0	Input Config 1		
201	0~7	enum	1	Input Config 2		
202	0~7	enum	2	Input Config 3		
203	0~7	enum	3	Input Config 4		
204	0~7	enum	4	Input Config 5		
205	0~7	enum	5	Input Config 6		
206	0~7	enum	6	Input Config 7		
207	0~5	enum	0	Relay Config 1		
208	0~5	enum	1	Relay Config 2		
209	0~5	enum	2	Relay Config 3		
210	0~5	enum	3	Relay Config 4		
211	0~5	enum	4	Relay Config 5		
212	0~5	enum	5	Relay Config 6		
213	0~63	enum	0	Relays Setup		Change the logic state of a relay. i.e. if Relay Config1 is Opened and this parameter is 1, the relay is active when the door is not open and not active when the door is not opened. Mask of available relays: Relay1 1, Relay2 2, Relay3 4, Relay4 8, Relay5 16, Relay6 32.
214	0~7	uint16	7	Input Config 8		

7.5 Functions

N°	Range	Type	Default	Name	Unit	Description
300	0~1	uint16	0	Input Mode		2 inputs: Close input means close, Open input means open / 1 input: Close input active means close, not active means open. Open input not used.
301	0~1	enum	0	Priority		Applied when both Open and Close inputs are active.
302	0~1	uint16	0	First Open Slave		Auto: at power on the door searches automatically for end position / Wait: a slow movement to search for the end position is done only when an open or closed commands is received.
303	0~1	enum	0	Slow Open		If On and both Open and Slow Close inputs are active, the door performs an open movement at slow speed.
305	0~1	uint16	0	Close Anticipated		Off: The Close state is set when the clutch is completely engaged On: The Closed state is set when the door panels are closed but the clutch is not yet engaged.
306	0~1	uint16	0	Close Is Bypass		Off: The Closed state is active when the position of the door is closed, according to Close anticipated parameter. On: the Closed state is active when Bypass input is active. The door position and Close anticipated parameter are ignored.
310	0~1	uint16	0	Eco Mode		Off: When the Close command is active, the door remains closed On: the door returns to standby after 30s in Closed state, even if Close command is active.
311	0~1	uint16	0	Clutch Release		Enable: when the door is closed and returns to standby, the clutch is disengaged with a controlled movement / Disable: if the clutch is engaged and the door returns to standby, the clutch is immediately released.
314	0~2	uint16	0	Control Mode		Slave: after a close obstruction, the door remains stopped until an Open or Reopen command is active /Master: after a close obstruction, the door reopens automatically and the Open state is active /Open only: after an obstruction, the door remains stopped until an Open command is active. ReOpen is ignored.
315	0~1	uint16	0	Disable slow down after obstruction		Off: in the next closing movement after a close obstruction, the door slows down before the previous obstruction/ On: the next closing movement after an obstruction is a normal close.
316	0~1	uint16	0	Open after Self Learn		Off: after the Selflearning procedure, the door remains in standby at close position with clutch disengaged / On: after Selflearning, the door remains open.
317	0~1	uint16	1	Opening Obs.		Off: no obstruction detection is applied on opening. On: an obstruction during movement is detected, the door stops and waits for a close command.

7. Parameters

7.6 Informations

N°	Range	Type	Default	Name	Unit	Description
400	0~4.295 ⁹	uint32	0	Serial Number		
401	0~10 ⁵	float	0,2	Software Version		
402	0~10 ⁵	float	0,2	BLE Version		
403	0~10 ⁵	float	0,1	Hardware Version		
404	0~1	uint16	0	Access Level		
405	0~4.295 ⁹	uint32	0	Password		

7. Parameters

7.7 Door Status

N°	Range	Type	Default	Name	Unit	Description
500	0~4095	bitword	0	Door Status		1 Opened 2 Closed 4 Opening 8 Closing 16 Reopen 32 Obstruction 64 Lightbarrierfault 128 OVERTEMP 256 Learning 512 Alarm 1024 Controller 2048 NoWrite 4096 Warning
501	0~10 ⁵	int16	0	Position	[mm]	0 when the panels are closed but the clutch is disengaged. Equal to -Clutch Length when the clutch is engaged, equal to Open Length when the door is completely open.
502	-1000~10 ²	float	0	Speed	[m/s]	Measurement of the absolute value of the instantaneous speed of the door.
503	0~10 ⁵	float	0	Torque	[Nm]	Measurement of the absolute instantaneous torque applied by the motor.
504	0~10 ⁵	float	0	Power In	[W]	Estimation of electrical power at input.
505	0~10 ⁵	float	0	Power Out	[W]	Measurement of electrical power applied to the motor.
506	0~400	float	230	Input Voltage	[Vac]	Measurement of voltage at the input connector.
507	0~10 ⁵	float	0	Friction		Estimation of friction of movement, done at SelfLearning.
508	0~1,5 ²	float	0	Doorlink Temp[°C]	[°C]	Measurement of temperature at the power module.
509	0~1,5 ²	float	0	Motor Temp[°C]	[°C]	With PM10 and induction motor: estimation of motor temperature With new motor: value of max of estimation and sensors embedded in motor.
510	0~4.295 ⁹	uint32	0	Active Alarms e warnings (in genere anomalie)		1 Doorlink overtemp 2 Motor overtemp 3 LightBarrierFault 4 Undervoltage 5 PowerFault 6 Encoder 7 Belt is broken 8 CAN Bus off 9 CANopen error 10 Phasing error 11 Self learning error 12 Overvoltage error
511	0~500	float	0	DCLink voltage	[Vdc]	Measurement of DCLink
512	0~4.295 ⁹	uint32	0	Current Time	[s]	Number of seconds since 00:00 of 1 Jan 2024
513	0~127	uint16	0	Input Status		Bitword, status of inputs. Independent of programmed function.
514	0~63	uint16	0	Output Status		Bitword, status of outputs.
515	0~255	uint16	0	Self Learn State		0 None 1 Motsearch 2 Phasing 3 Rs 4 Searchpos 5 Hold1 6 Searchneg 7 Hold2 8 Searchdir 9 Askpos 10 Clutch 11 Inertia 12 Askconfirm 13 Error 14 Done
516	0~900	float	0	Max Open Speed	[mm/s]	(Read Only) maximum value for 106 "Open speed"
517	0.0001~1000	float	0	Max Open Acceleration	[m/s ²]	(Read Only) maximum value for 108 "Open acceleration"
518	0~900	float	0	Max Close Speed		Limit for the closing speed
519	0.0001~1000	float	0	Max Close Acceleration		Limit for the opening acceleration
520	0~900	float	0	Max Slow Speed	[mm/2]	(Read Only) max value for "Close Slow Speed"
521	0~1.0E+9	float	0	Length at Open Speed	[mm]	(Read Only) Distance traveled at maximum speed
522	0~1.0E+9	float	0	Length at Close speed		Distance traveled at maximum speed

7. Parameters

7.8 Counters

N°	Range	Type	Default	Name	Unit	Description
601	0~10 ⁸	float	0	Working Hours		Number of hours at power up
602	0~10 ⁸	float	0	Total Cycles		Number of movements, either opening or closing
603	0~10 ⁸	float	0	Powerups		Numer of power ups
604	0~10 ⁸	float	0	Learning cycles		Number of times the Self Learning procedure has been executed
605	0~10 ⁸	float	0	Reopenings		Number of times the Reopen input has been activated or the door has reopened in master mode
606	0~10 ⁸	float	0	Short~circuits		Number of short circuit alarms
607	0~10 ⁸	float	0	Overcurrents		Number of over current alarms
608	0~10 ⁸	float	0	Undervoltages		Number of undervoltage alarms. N.B.: powering off the Doorlink is considered a normal operation, it does not generate an alarm. Check "Powerups" to understand if unwanted power failures are occurring.
609	0~10 ⁸	float	0	Light curtain faults		Number of times the light curtain faults inputs has been activated
610	0~10 ⁸	float	0	Doorlink overtemps		Number of times the Doorlink overtemp warning has been generated
611	0~10 ⁸	float	0	Motor overtemps		Number of times the Doorlink overtemp warning has been generated
612	0~10 ⁸	float	0	Opening Obstructions		Counter of opening obstructions
613	0~10 ⁸	float	0	Closing Obstructions		Counter of closing obstructions

7. Parameters

7.9 Advanced Configuration

N°	Range	Type	Default	Name	Unit	Description
800	0~1	uint16	0	Save Config		0=Off 1=On After writing any parameter, se this to 1 to make the change permanent after power up, otherwise all changes are lost
801	125~1000	uint16	250	CAN Baudrate	[kbps]	Valid values are 125, 250 , 500, 1000
802	1~255	uint16	7	CAN NodeId		CANopen node identifier
803	0~4.295 ⁹	char	Doorlink100	BLE Name		
804	0~1	char	1	CAN protocol		CANopen: only CANopen protocol is active /Legacy: both CANopen and legacy CAN protocol are active.

8. Alarms and Warnings

8.1 Alarms and Warnings

Alarm Code	Mask for parameters 510 "Alarms & Warnings"	Alarm Description
1	0x10	Doorlink overtemp
2	0x20	Motor overtemp
3	0x40	Light Barrier Fault
4	0x80	Undervoltage
5	0x100	Power Fault
6	0x200	Encoder
7	0x400	Belt is broken
8	0x800	CAN Bus off
9	0x1000	CANopen error
10	0x2000	Phasing error
11	0x4000	Self learning error
12	0x8000	Overvoltage error

Warning Code	Mask for parameters 510 "Alarms & Warnings"	Warning Description
17	0x100000	Undervoltage Warning
18	0x200000	Obstruction
19	0x400000	Friction
21	0x800000	Offset error
22	0x1000000	BLE error
23	0x2000000	Overvoltage warning
24	0x4000000	Doorlink overtemp warning
25	0x8000000	Encoder warning
26	0x10000000	Motor overtemp warning

SICOR ITALY
AN  **ELEVANTIS COMPANY**



Sicor Italy S.R.L.

Viale Caproni, 32 Rovereto (TN) - Italy · Tel: +39 0464 484 111 · info@sicoritaly.com

www.sicoritaly.com

Products' specifications included in this brochure are subject to change by Sicor without notice.